



# Sustainable housing design: A case study of existing and new build affordable housing

*The Changing Streams Research Centre  
The University of Liverpool*

*Dr Gareth Abrahams*

*December 2023*

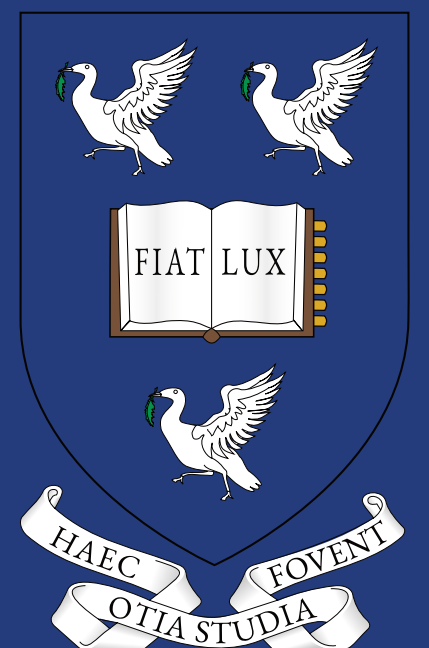

# Executive summary

This document presents the outputs produced for a 2-year research project. This project is funded by one of the leading affordable housing companies in the North of England, Your Housing Group and is delivered by the University of Liverpool with input from Changing Streams CIC.

The focus of this project is to develop new insight and ideas for improving the sustainability of homes delivered and maintained by YHG. This includes the design of new-build houses (Part 1), the refurbishment of existing housing stock to improve energy performance (Part 2) and opportunities to improve energy consumption on an individual tenant basis through targeted education / communication pieces (Part 3).

This executive summary presents some of the main findings of the study. These points are developed in far greater depth through the respective sections of the document.

## Part 1: New build

### Operational energy, embodied carbon and plastic in new build housing.

- This study provides a novel methodology for assessing operational energy, embodied carbon, and plastic on schemes where the information needed to form such assessments is incomplete. This study recommends that a similar method could be employed by YHG in future research projects and integrated into their design review process.
- This study identifies areas of thermal bridging and breaks in the air-tightness layer in 'typical' strip sections used for new-build housing.
- The study identifies the embodied carbon and plastic content for all specified products identified in strip sections of a 'typical' house-type.
- Building on these findings, the study suggests that YHG should consider expanding their standard Employer Requirement documents to ensure all designs are assessed to identify thermal bridging, airtightness breaks, embodied carbon and plastic content.
- This study reveals limitations associated with the availability of data found in the Environmental Product Declaration (EPD) to assess embodied carbon and plastics. The study recommends several, general actions that could be taken by YHG to position itself as an industry leader in this area.

## Part 2: Existing housing stock

### Improving the energy performance of existing housing stock.

- This study reviews a database of all YHG existing housing stock. The analysis of this data is used to establish six assembly types each containing variations for wall, floor and roof components. Findings from this research suggests that this typological approach would be a suitable method for YHG to develop further.
- The study identifies three typologies that cover large quantities of stock and demonstrate very poor thermal performance. The study suggests that future research and refurbishment strategies should focus on these.
- The study reviews the limitations of the YHG database and identifies an opportunity to expand this database by collating and integrating data from Energy Performance Certificate (EPC) assessments. The study collects, collates, and integrates EPC for 3k units and recommends that YHG should extend this exercise to include all 22k units.
- An initial analysis of the expanded dataset identifies the energy usage for the least thermally performant homes across YHG stock profile. This analysis suggests that tenants would need a gross household income of over £21k to avoid fuel poverty based on this EPC performance data. Future research is needed to test the accuracy of this data / findings and to better understand the factors that underpin it.

## Part 3: Communication

### Communicating with tenants to help them reduce energy and plastic use.

- In collaboration with YHG, the study documents the results of an extensive survey of existing tenants. This survey revealed a strong case for producing and disseminating targeted education / communication pieces to reduce energy and plastic use. Further research could be used to improve this survey data. This may include semi-structured survey questions or/and semi-structured interviews.
- Based on the findings from the survey the research team produced several thematic education / information pieces. This report presents extracts from these documents. It recommends that YHG should review these documents and, if appropriate, edit and disseminate them as part of a pilot study.

# Structure and aims of the study

## Part 1: New build

### Operational energy, embodied carbon and plastic in new build housing.

The aim of the first project stage was to review the operational energy, embodied carbon and plastic in a new-build housing type and identify opportunities for improvement.

This aim was achieved by:

- Identifying a 'typical' house-type used for new-build developments by YHG
- Assessing the envelope design of this 'typical' house-type in terms of operational energy
- Assessing the materials used in the design of this 'typical' house-type in terms of embodied carbon
- Assessing the materials used in the design of this 'typical' house-type in terms of embodied plastics
- Using this insight to identify opportunities for improving the design

## Part 2: Existing housing stock

### Improving the energy performance of existing housing stock.

The aim of the second project stage was to review existing housing stock and identify opportunities to improve energy performance and to reduce fuel poverty.

This aim was achieved by:

- Reviewing a database of over 22k units to identify a sample
- Establishing a typology of typical assemblies and junctions (wall-to-floor, wall, wall-to-roof) relevant to these house-types
- Reviewing the operational energy (u values) of these typical assemblies and limitations in their design
- Expanding this database to include EPC data
- Using this data to identify issues associated with energy use and fuel poverty
- Identifying opportunities / strategies for improvement

## Part 3: Communication

### Communicating with tenants to help them reduce energy and plastic use.

The aim of the third project stage was to explore opportunities to reduce energy and plastic use through targeted communications with tenants.

This aim was achieved by:

- Collecting data from a large sample of existing YHG residents based on their energy and plastic use
- Reviewing / analysing this data to establish core themes
- Using the data to identify targeted education pieces for YHG residents



## Part 1: New build

### **Operational energy, embodied carbon and plastic in new build housing.**

The aim of the first project stage was to review the operational energy, embodied carbon and plastic in a new-build housing type and identify opportunities for improvement.

This aim was achieved by:

- Identifying a 'typical' house-type used for new-build developments by YHG
- Assessing the envelope design of this 'typical' house-type in terms of operational energy
- Assessing the materials used in the design of this 'typical' house-type in terms of embodied carbon
- Assessing the materials used in the design of this 'typical' house-type in terms of embodied plastics
- Using this insight to identify opportunities for improving the design





The aim of the first project stage was to review the operational energy, embodied carbon and plastic in a new building housing type and identify opportunities for improvement.

This aim was achieved by:

- Identifying a 'typical' house-type used for new-build developments by YHG
- Assessing the envelope design of this 'typical' house-type in terms of operational energy
- Assessing the materials used in the design of this 'typical' house-type in terms of embodied carbon
- Assessing the materials used in the design of this 'typical' house-type in terms of embodied plastics
- Using this insight to identify opportunities for improving the design

### How to identify a 'typical' house-type?

During the exploration phase of the study (1-3 months) the research team met with key stakeholders from YHG to ascertain a suitable site and house-type to serve as the baseline for the audit.

### *Why focus on a single house-type as a case study for this project?*

YHG is one of the largest Affordable Housing companies in the UK and certainly in the North West of England. This housing provision is not developed for a single household demographic or planning context. As such, YHG must build a range of housing types suitable to different household needs and different contexts. Whilst this housing may meet similar criteria, regulations and guidance these differences mean that housing designs will vary across YHG's new-build stock. Because of this variation, one house-type will not be directly comparable to another in terms of its sustainability credentials. It is not feasible within the limitations of a single study of this kind to consider all variants. A case study approach provides a fair and reasonable method for overcoming this diversity.

### **A case study strategy**

The success of a case study-based projects rests on the selection process and the reasoning behind this selection. There are many ways to form this selection depending on the intended outcomes of the project. In this instance, the research aims to develop insight about new build-housing design that could be applied to the majority of new-build housing stock. Given the level of detail required for this purpose, it was decided that the scope of this study should be limited to a single house-type.

After reviewing the YHG portfolio of newly built properties and a database of over 22 thousand existing housing units, the project team observed that the majority of new-build and existing stock were design as (or at least functioned as) 3-bed, 5-person houses.

The case study strategy was, thus, conceived around the selection of a suitable 3B5P house-type.

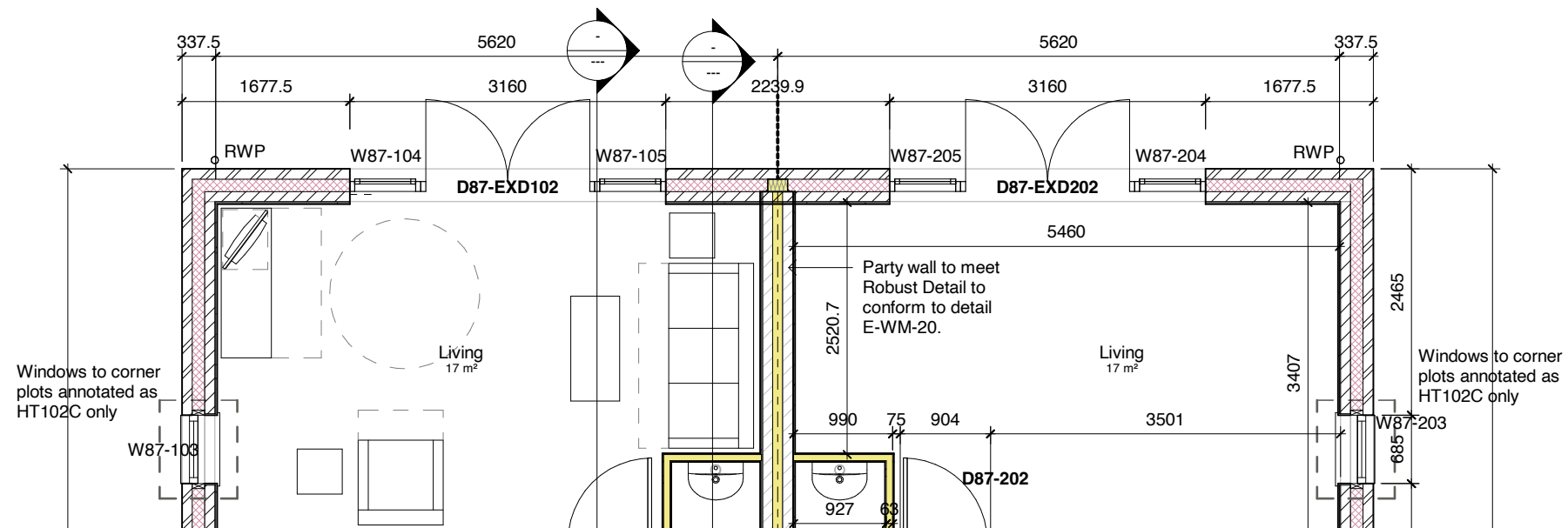

## House-type 87: A case study

### Selecting a specific 3B5P house-type as a case study

After discussion with key members of YHG's leadership and procurement teams, it was noted that the company do not own or build-out their own, standard house-types. In this procurement model, YHG identify limited performance criteria and specifications as part of their Employers Requirements (ER) document. The responsibility for producing house-types that align with these ERs rests with an external design team. As part of a tender bid, all designs must demonstrate alignment to the ERs and (where appropriate) identify all derogations against these documents and all associated guidance and standards indicated therein (such as the Housing Quality Standards).

This procurement model ensures that the responsibility for all design related issues rests with external parties / design team. It also ensures some degree of design variation across all YHG sites.

However, this procurement model also introduces complexities associated with the selection of a representative house-type for this project, and, in implementing holistic sustainability focused design solutions and requirements across all future housing stock. This limitation was noted in the early exploratory stages of the project.

### Overcoming these limitations

To overcome these limitations, the project team identified multiple sites where 3B5P housing had been / proposed to be built. This formed the basis for several workshops with various members of the YHG team. After selecting an overall sample, the research team undertook a brief review of each option using the following considerations:

- *Alignment between the design and the ERs.* The research team selected a house-type that did not include any derogations that would limit its use in further studies.
- *The layout of rooms and any space planning limitations.* This consideration was particularly relevant to house-types which included rooms in the roof. It is fair to assume that some of the design modifications inferred from this project would suggest increasing the thickness of thermal insulation in the roof space, and in more robust airtightness detailing. This would have an impact on viability.
- *Copyright.* After discussing the sample of house-types selected, YHG advised which of these designs could be used by YHG without obtaining special permission from the design team. This third consideration was relevant to the motivation and philosophy underpinning this study. As agreed during the early project discussion stages, the outputs of this research project are intended to be open / publicly accessible.

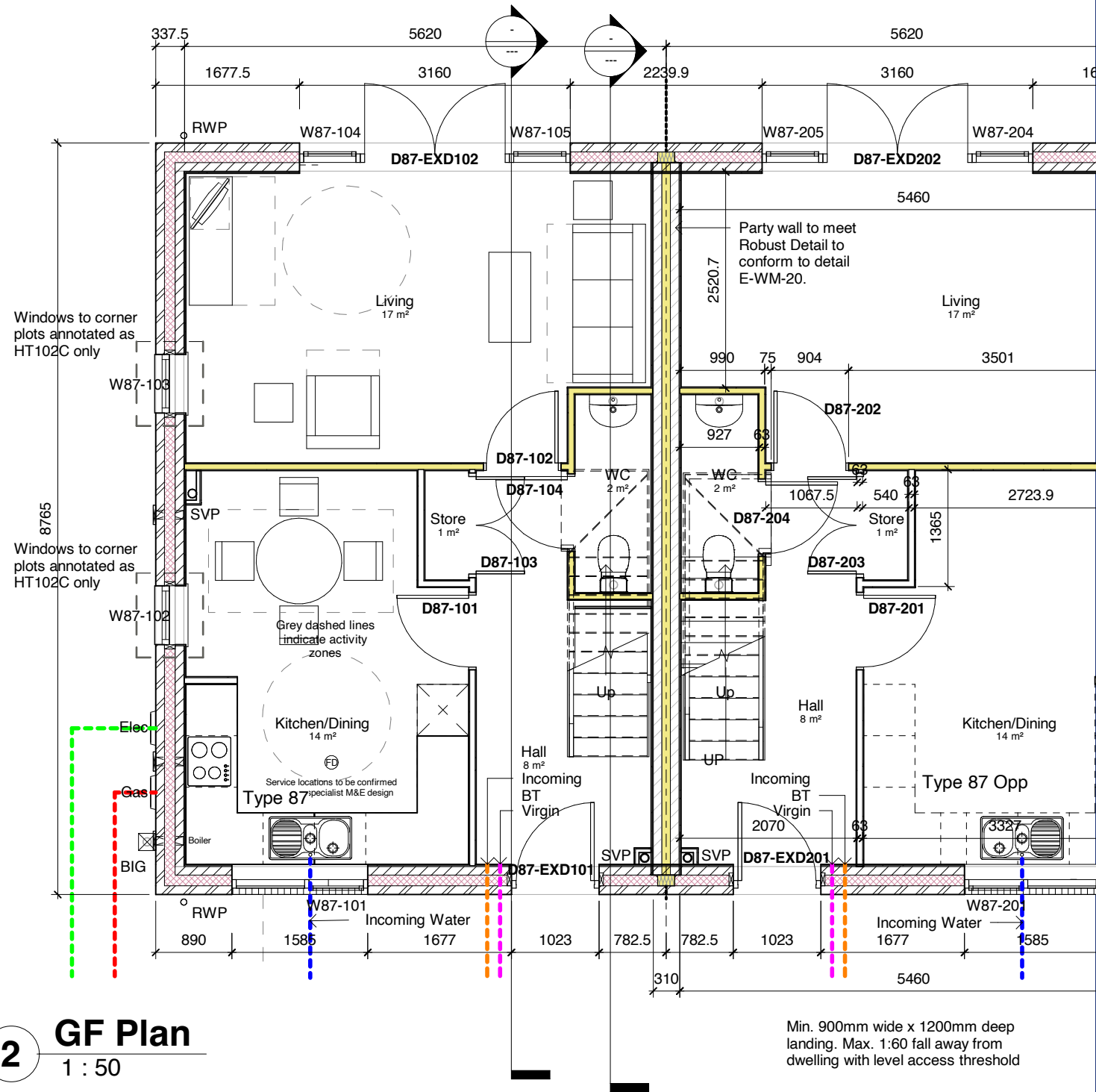

**2 GF Plan**  
1 : 50

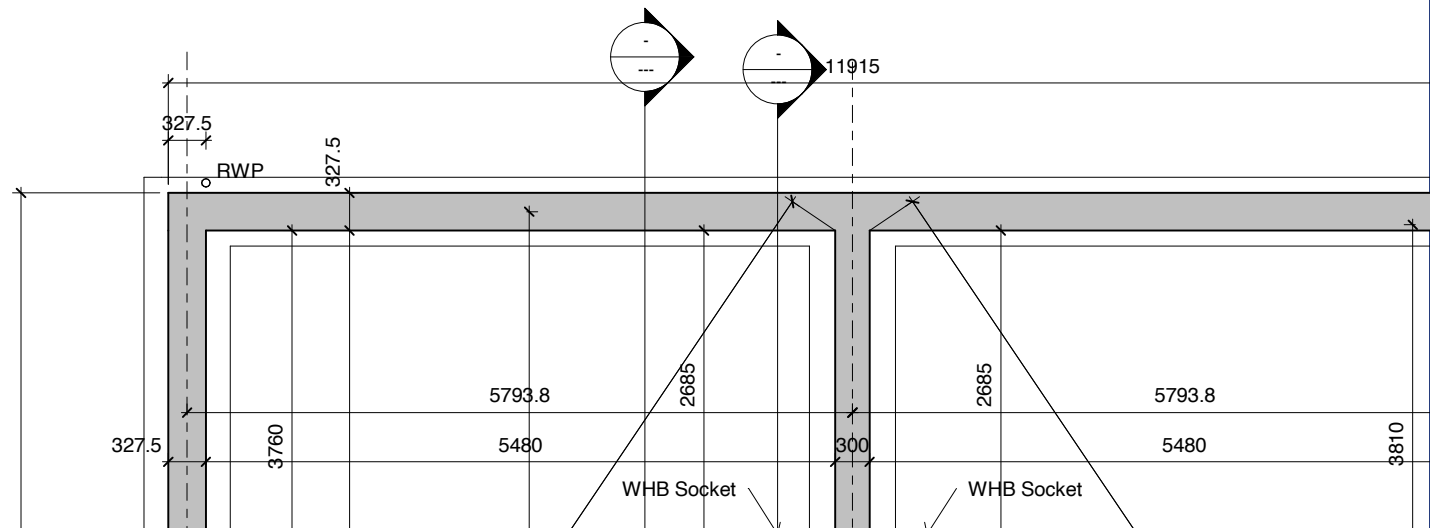

### The drawings and specifications as data

YHG provided the research team with a copy of all drawings of the house-type produced for tender purposes. These drawings are intended for tender purposes only and to provide the contractor with sufficient information to develop a cost plan for the bid. This information was not intended for use as data in a sustainability appraisal.

After assessing the completeness and appropriateness of this information for this assessment, the research team found that much of the data needed for a complete and thorough assessment was missing. This data included:

- A full NBS specification.
- A complete cost model or Bill of Quantities.
- A complete set of drawings to identify all detailing and the size and scale of all products used in each.

To undertake a thorough and complete assessment of sustainability, the assessor needs a complete NBS specification to ensure all products are included. They need a Bill of Quantities or a detailed cost model to quantify the number of these products in the scheme.

The detailed drawings are important because it shows the assessor where the products are used. This is particularly important when we are considering the sustainable performance of the design i.e. operational energy. It is also important for any follow-on considerations. Namely, how this product might be best exchange with another lower carbon, lower plastic-based material.

Without this data, it is not possible to produce a robust and complete audit of the scheme.

However, whilst this may be problematic for assessment, it is not uncommon in the construction industry. Unless a design team is asked to produce this information, most schemes will only include information required for the purposes of the tender and pricing. By producing the level of information needed for this stage only, the team are able to offer a cost and time effective way to move through the RIBA stages of work.

This observation is important if this assessment is to have an influence on YHG's future new-build housing stock. Unless YHG provide additional, directed funding for the design team to meet the specific requirements of assessment, we can assume that all future assessments and design measures are likely to have these same limitations.

On this basis, the research team revised the data and case study strategy to overcome these gaps and omissions.

## Producing a strategy for using the data based on the information available

This revised strategy was developed in two stages:

### ■ Representative sections

Whilst the data is not sufficient to consider all materials used for all details that relate to all parts of the building, it does provide sufficient information to establish several representative sections.

On this basis, the research team identified six typical assemblies within the built envelope. These are as follows:

- A** A strip section through the typical window arrangement to ground and first floor to the front of the house.
- B** A strip section through a wall running across both floors at the front of the house.
- C** A strip section through a door at ground floor and a window at first floor to the front of the house.
- D** A strip section through the wall running across both floors forming the gable wall.
- E** A strip section through the window screen to the ground floor and window to first floor to the rear of the house.
- F** A strip section through the party wall to the centre of the house.

Taken together these 6 strip sections represent all variants of the envelope within this typical house-type.

### ■ Advantages of an assessment focused on sections rather than a full house-type.

Focusing on these sections from the case study rather than the full house-type provides several important advantages.

Given we do not have sufficient data to consider the full scheme these sections provide us with a workable sample.

By studying each section using a nominal depth of a linear metre, these sections provide us with an embodied carbon and embodied plastic figure that we can use to compare one section against another.

This ensures robustness, but it also provides some practical benefits. It means that we can then use this data in the design process to consider different options: extending a wall and reducing the width of a window or swapping a window screen with a window for example.

It also allows us to assess many different house-types that use the same sections. In such instances, we simply multiply 1 linear metre by the actual length of the section as designed.

*It should be noted that this methodological has not been used before and could be used by many others working in this area to offer a practical solution to assessing real-world schemes that do not include all required data.*

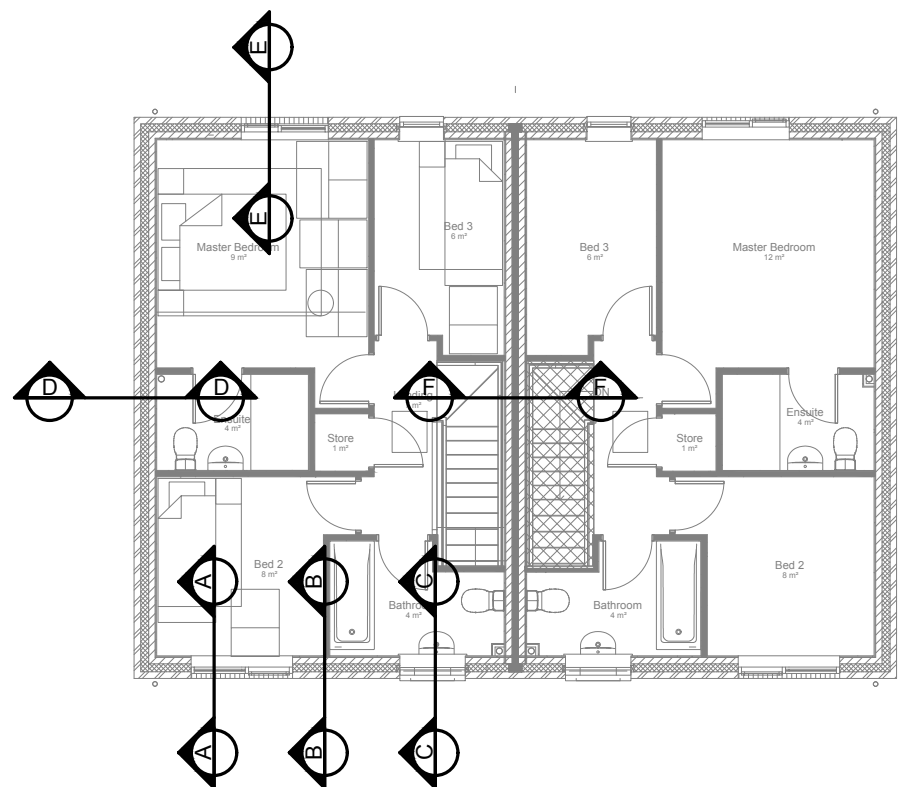
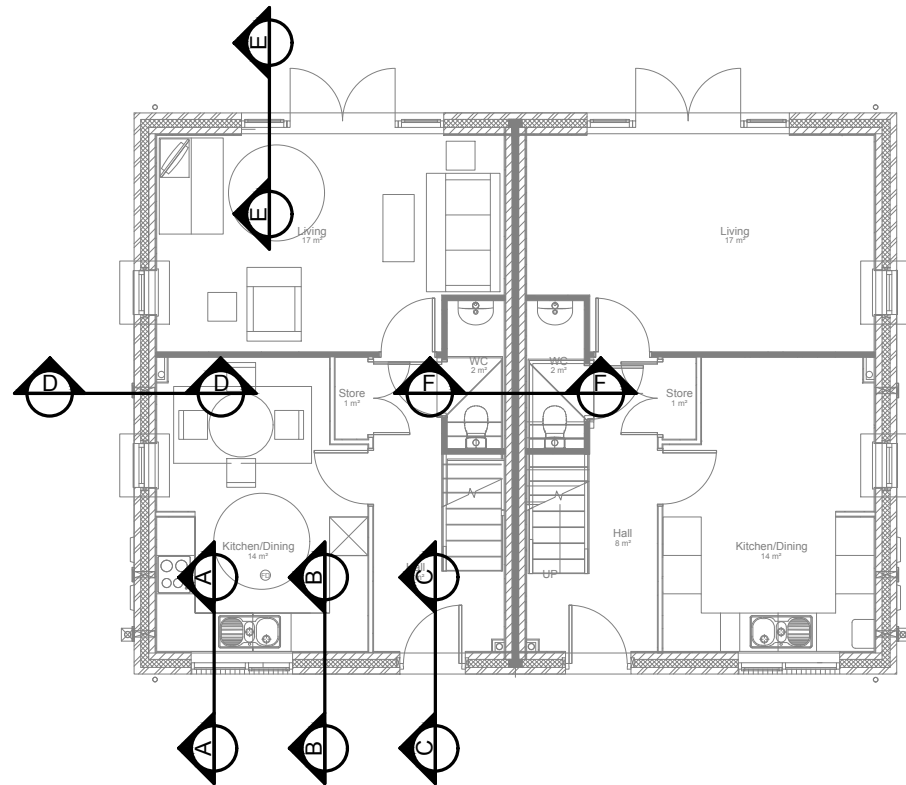

Figure 1: strip sections through floor plan



### ***Adapting and extending the data***

To produce these 6 section types, the research team had to adapt and extend the data (drawings and specifications) provided by YHG.

Four kinds of adaptations and additions were made:

- *Drawings.* The drawings provided did not cover all 6 sections. To overcome this, the research team adapted and re-drew existing details and drew new sections to suit.
- *Drawings.* The drawings provided by the architect provided two sets of details. Most of these details were produced to meet Part L regulations enforceable at the point of tender / contract and were to be used for construction. The architect also produced variations of these details that were intended to meet a subsequent revisions to Part L introduced for 2021 and applicable as of June 2023 (18 months into the research project). The architect developed this second set of details as a pilot initiated by YHG. This was used to test and identify the costs and viability of this higher standard. Given that these second details reflected an improved standard that would be applicable after the completion of the study, the research team decided to incorporate these higher performance details into the 6 sections. To do this, the research team needed to adapt and re-draw all 6 sections to suit.
- *Specifications.* All specification in this scheme were highlighted on drawings rather than in an NBS document. To overcome this, the research team compiled all specification notes into a central document and then used these to populate the 6 newly formed sections.
- *Specifications.* As with most projects at this RIBA stage of work, the architect only specifies principal products. It is assumed that all other products will be selected during subsequent stages of work. This selection may be made by members of the design team or contractor team. For the purposes of this study, these gaps were problematic. Not least because these products may contain high levels of embodied carbon or/and plastics. With this in mind, the research team extended the specification to include products there were inferred in the detailed drawings or were typical within the construction industry. This relied on the extensive industry experience of the research team.

# 6 strip section types

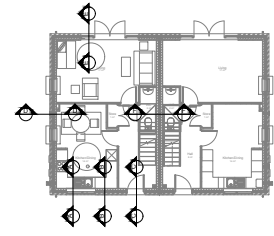

Ground Floor Plan

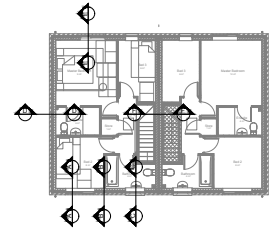

First Floor Plan

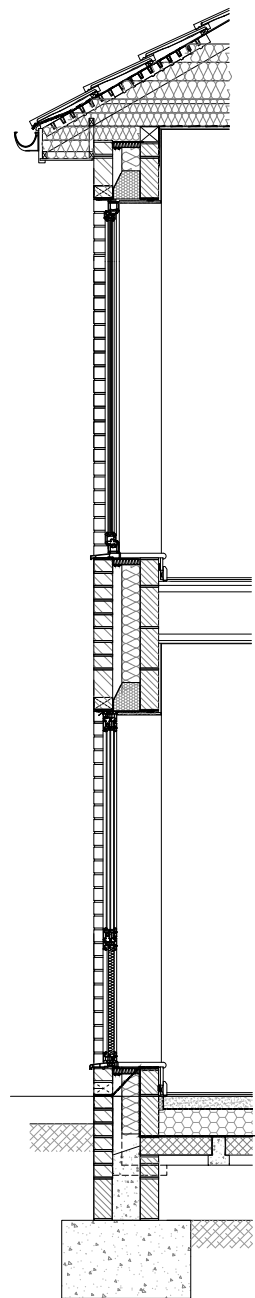

Section A - A

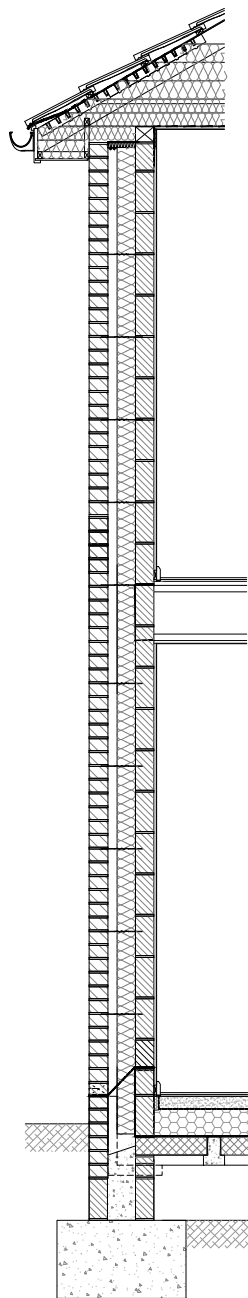

Section B - B

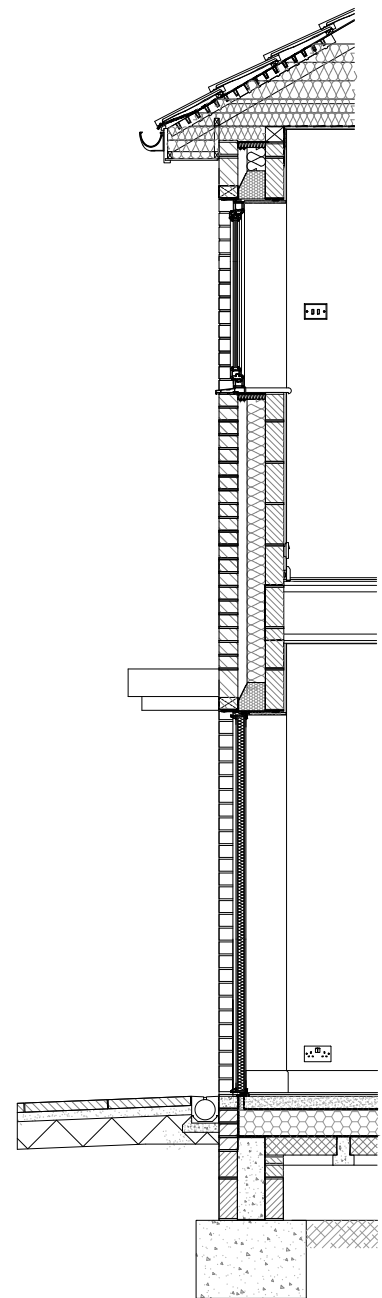

Section C - C

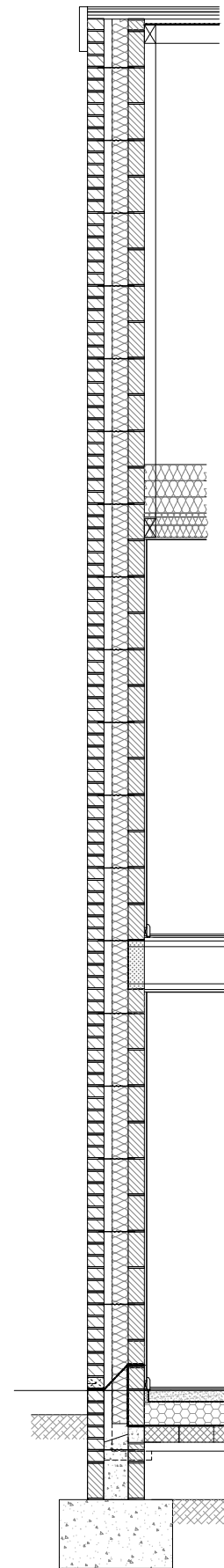

Section D - D

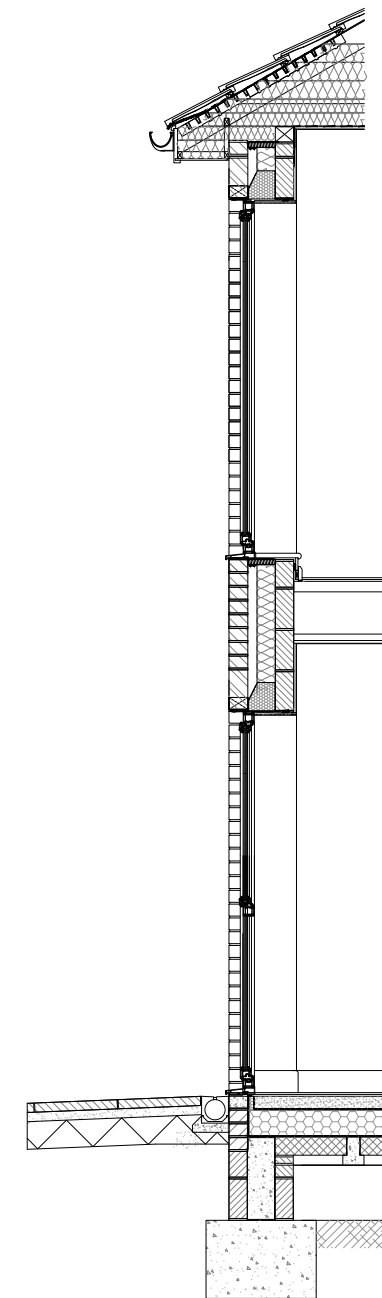

Section E - E

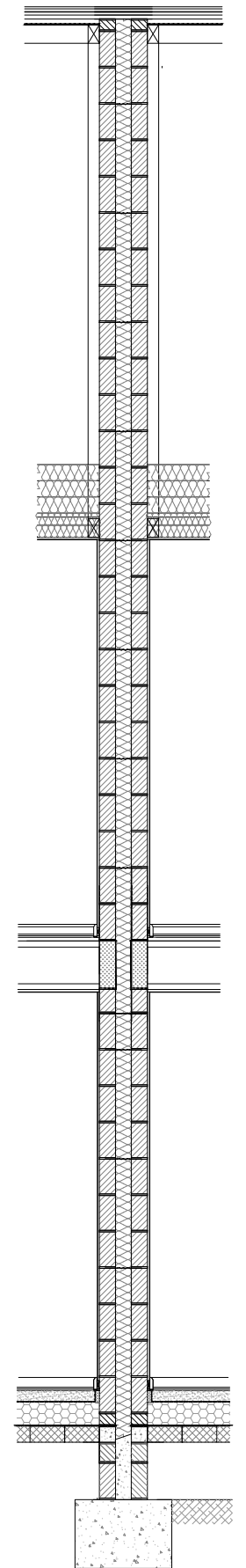

Section F - F

Figure 2: strip sections as typologies

The aim of the first project stage was to review the operational energy, embodied carbon and plastic in a new-build housing type and identify opportunities for improvement.

This aim was achieved by:

- Identifying a 'typical' house-type used for new-build developments by YHG
- Assessing the envelope design of this 'typical' house-type in terms of operational energy
- Assessing the materials used in the design of this 'typical' house-type in terms of embodied carbon
- Assessing the materials used in the design of this 'typical' house-type in terms of embodied plastics
- Using this insight to identify opportunities for improving the design

### How to assess the operational energy of the 6 section types

Once these section types were identified and produced, the next stage was to assess these designs in terms of operational energy. There are many different features of a building's use that would contribute to the amount of carbon energy needed for its operation. These include: lighting, heating, ventilation, cooling and general power usage.

This assessment focused on heating. And, more specially, on the design of the envelope as a primary contributor to thermal performance. This scope thus focuses on the architectural design and detailing rather than the mechanical and electrical design (M+E).

The research team assessed the operational energy of the design in two stages:

- The first stage was to assess the U-value of key building assemblies (walls, roofs, floors) of the case study using PhPP modelling software. The aim of this exercise was to ensure that the design met the target U-values within Building Regulations, and to see how this compares against target U-values identified by the Passive House Standard (largely seen as the most effective standard to achieve carbon zero targets through thermal envelope design).
- The second stage was to undertake a design assessment of the 6 section types to consider issues that would impact thermal performance regarding air-tightness and thermal bridging.

The research team identified a third stage of research that could be implemented in further research. This third stage would have used the information from Stages 1 and 2 to produce a complete thermal model of the scheme using PhPP. This comprehensive software would have provided important insight into the extent and impact of cold-bridging within the scheme and the total operational energy demands of the scheme based on the envelope and spatial design as well as the mechanical and electrical design / specification.



Table 1.1 Summary of notional dwelling specification for new dwelling <sup>(1)</sup>	
Element or system	Reference value for target setting
Opening areas (windows, roof windows, rooflights and doors)	Same as for actual dwelling not exceeding a total area of openings of 25% of total floor area <sup>(2)</sup>
External walls including semi-exposed walls	U = 0.18 W/(m <sup>2</sup> ·K)
Party walls	U = 0
Floors	U = 0.13 W/(m <sup>2</sup> ·K)
Roofs	U = 0.11 W/(m <sup>2</sup> ·K)
Opaque door (less than 30% glazed area)	U = 1.0 W/(m <sup>2</sup> ·K)
Semi-glazed door (30–60% glazed area)	U = 1.0 W/(m <sup>2</sup> ·K)
Windows and glazed doors with greater than 60% glazed area	U = 1.2 W/(m <sup>2</sup> ·K) Frame factor = 0.7
Roof windows	U = 1.2 W/(m <sup>2</sup> ·K), when in vertical position (for correction due to angle, see specification in SAP 10 Appendix R)
Rooflights	U = 1.7 W/(m <sup>2</sup> ·K), when in horizontal position (for correction due to angle, see specification in SAP 10 Appendix R)
Ventilation system	Natural ventilation with intermittent extract fans
Air permeability	5 m <sup>3</sup> /(h·m <sup>2</sup> ) at 50 Pa
Main heating fuel (space and water)	Mains gas
Heating system	Boiler and radiators Central heating pump 2013 or later, in heated space Design flow temperature = 55 °C
Boiler	Efficiency, SEDBUK 2009 = 89.5%
Heating system controls	Boiler interlock, ErP Class V Either: – single storey dwelling in which the living area is greater than 70% of the total floor area: programmer and room thermostat – any other dwelling: time and temperature zone control, thermostatic radiator valves
Hot water system	Heated by boiler (regular or combi as above) Separate time control for space and water heating
Wastewater heat recovery (WWHR)	All showers connected to WWHR, including showers over baths Instantaneous WWHR with 36% recovery efficiency utilisation of 0.98
Hot water cylinder	If cylinder, declared loss factor = 0.85 × (0.2 + 0.051 V <sup>2/3</sup> ) kWh/day where V is the volume of the cylinder in litres
Lighting	Fixed lighting capacity (lm) = 185 × total floor area Efficacy of all fixed lighting = 80 lm/W
Air conditioning	None
Photovoltaic (PV) system	For houses: kWp = 40% of ground floor area, including unheated spaces / 6.5 For flats: kWp = 40% of dwelling floor area / (6.5 × number of storeys in block) System facing south-east or south-west

**NOTE:**  
1. For a dwelling connected to an existing district heat network, an alternative notional building is used. See paragraph 1.8 and SAP 10.  
2. See SAP 10 for details.

Figure 3: extract from Building Regulations Part L

## Stage 1: assessing U-values for the the baseline sections

### Calculating and comparing U-values in the sections / assemblies

#### External and party Walls:

##### External walls

Architect's drawings and spec note identify the wall build-up as:

- 102.5 facing brick outer leaf (0.7 W/(mK))
- 50mm cavity
- 100 Kingspan Kooltherm (0.018 W/(mK))
- 100mm Blockwork Plasmor Stranlite (or sim) (0.31W/(mK))
- 12.5mm Gyproc board (0.21W/(mK))
- Dabs (0.43W/(mK))

When added into a PHPP model this identifies

**0.159 W/m<sup>2</sup>/K for the wall build-up**

NB:

Part L of the Building Regulations 2016 requires: 0.26 W/m<sup>2</sup>/K

Part L of the Building Regulations 2021 requires: 0.18 W/m<sup>2</sup>/K

As such, this build-up improves upon the minimum required thermal standards

#### Floors

Architect's drawings and spec note identify the suspended floor as:

- 75mm fibre screed (1.05 W/(mK))
- Building paper
- 150mm Ecotherm Versal insulation (0.018 W/(mK))
- 1200 guage polythene DPM with 300 laps and up sides and lapped with DPC
- 100mm Plasmor Stranlite (7.3N) Beam and Block (0.41 W/(mK))
- Void

When added into a PHPP model this identifies

**0.137 W/m<sup>2</sup>/K for the floor build-up**

NB:

Part L of the Building Regulations 2016 requires: 0.18 W/m<sup>2</sup>/K

Part L of the Building Regulations 2021 requires: 0.13 W/m<sup>2</sup>/K

NB this suggests that the floor build-up does **not** meet U-values for Part L 2021. A slightly thicker depth of insulation (160mm) would meet this standard.

#### Roof

The architect's drawings do not state the thermal conductivity or quantity of mineral wool in the roof void. They show this insulation between joists and over joists.

But we can work backwards to calculate these components by assuming the detailed spec meets the building regulation standard.

Part L of the Building Regulations 2021 requires: 0.11 W/m<sup>2</sup>/K

If we assume Rockwool as per the Rockwool data-sheet. These come in 100mm rolls. If we assume that there is 100mm between joists (based on typical truss / joists depth) and 300 over, this provides a U value of 0.108 W/m<sup>2</sup>/K. This is better than the regulatory requirement.

## Stage 2: Design assessment of the assemblies

In Stage 1, the research team considered the thermal performance of key building assemblies. In Stage 2, the team focused on the specifics of the envelope design.

The integrity of the thermal envelope and, thus, the effectiveness of the insulation is highly dependent on two other factors:

- The location and extent of thermal bridging in the design
- The integrity of the air-tightness line.

This means that any costs and effort directed at improving the U-value of these assemblies is reduced if a building suffers with large areas of thermal bridging and breaks in the integrity of the air-tightness line.

### Thermal bridges:

The U-values considered in Stage 1 focused on a typical section of wall, floor or roof. However, these typical build-ups are not consistent across all areas of a thermal envelope. There are points in a building design when this thermal performance is reduced. At these points, heat transfer is increased because there is a direct passage from the inside to the outside of the building. These are referred to as thermal bridges or cold bridges and can be located at specific points or along lengths of the envelope.

After examining the 6 section types, the research team identified several zones with increased thermal bridging. It should be noted that these thermal bridges relate to the 6 section types rather than the building as a whole and thus, do not include geometric thermal bridging at the corners of the envelope for example.

- 1 There is a thermal bridge to the base of the wall / intersection with the floor build-up. This runs from the internal space through the plaster finish, to the inner concrete block in the wall build-up, through the concrete infill within the cavity space, to the external masonry, and leading to the unheated external air. The design has partly mitigated this thermal bridge by introducing a light-weight thermal block to the base of the internal leaf. Whilst this is normatively considered an effective solution, given that this block is far less performant than the insulation within the cavity it does represent a partial thermal bridge in the design.
- 2 The second thermal bridge relates to a risk of construction rather than through design. The thermal value of the wall assembly is entirely dependent on the thermal performance and integrity of the rigid insulation boards within the cavity. Technically these boards can provide high thermal performance if installed correctly and flawlessly. However, the smallest of gaps between abutting boards can have a significant impact on this performance, thus reducing the U-value far below that achieved through an insulation with higher thermal conductivity. Flawless installation is more difficult when we account for openings and intense build programmes. On this basis, we must allow for the risk of thermal bridging or thermal cold spots owing to this insulation specification. It should be noted that a variant of this detail used for the previous Part L standard uses loose fill thermal beading which does not suffer from these risks.
- 3 The third thermal bridge is located at the head and base details for the window. For the latter, this bridging moves from the inner room through the sill board, and along the connection between the window and the external masonry wall. Whilst the design includes a thin, high performance insulation layer across the cavity, this will not fully mitigate this thermal bridging. To the head detail this thermal bridging moves through the plaster along the connection between the window frame and the external masonry.
- 4 A fourth thermal bridge is located in the roof space and tracks along the ceiling joists to internal plasterboard. As with previous thermal bridges this is partly mitigated. By packing the roof space with mineral wool, this linear and repeating thermal bridge is reduced.

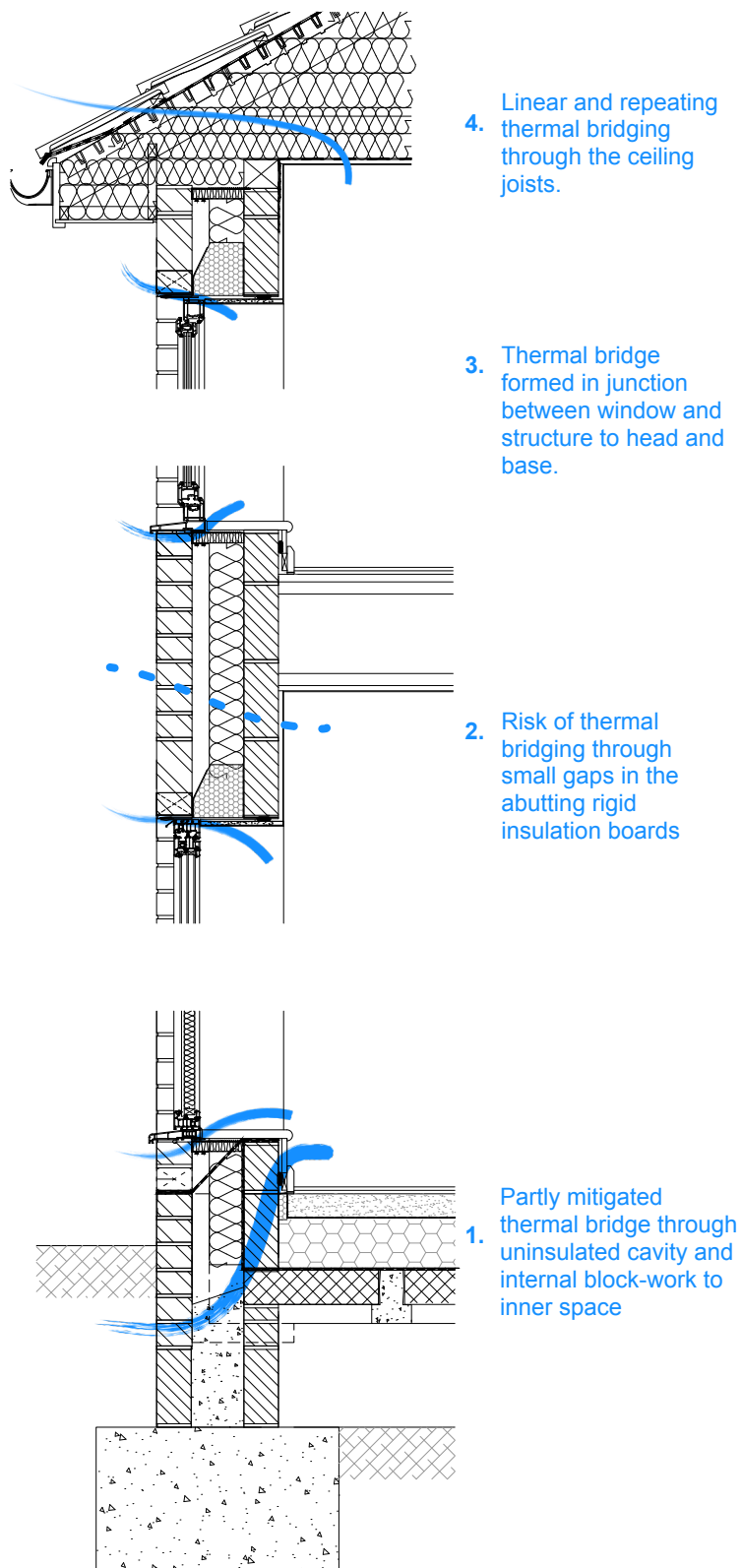
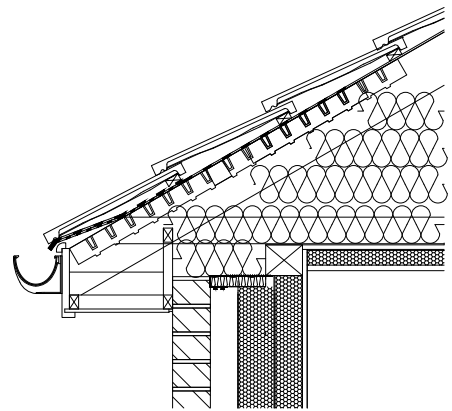
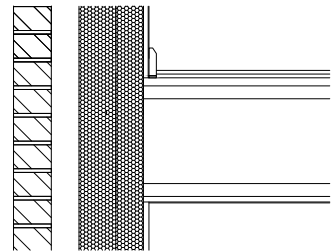

Figure 4: mark up showing thermal bridging in typical strip section



4. Continuous layer of thermal insulation below joists



3. Window is re-positioned to align with the wall insulation

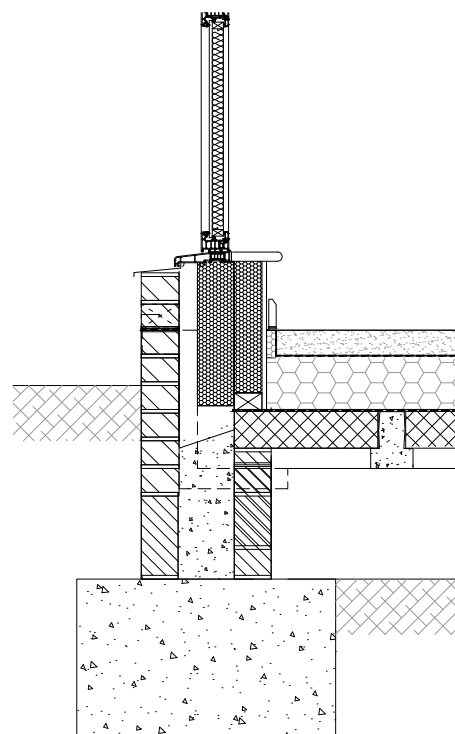

2. Semi-rigid mineral wool used instead of rigid abutting insulation

1. Exchange load bearing block-work with timber frame

## How do we further mitigate these thermal bridges?

The design demonstrates efforts to mitigate the thermal bridges identified by including insulation material alongside these lines of passage. Further design changes could be considered that would mitigate these further. These options are identified below and presented in the marked-up drawing overleaf.

One solution to reducing thermal bridging at the base detail is to exchange the load bearing inner masonry leaf with a load bearing timber frame with semi-rigid mineral wool fill and coupled with a semi-rigid mineral wool unbroken layer within the cavity. Not only would this reduce thermal bridging, the integrated insulation solution may reduce the thickness of the overall build up (depending on the thermal conductivity of the product selected).

This design solution would equally reduce the risks identified in the second thermal bridge. Rather than a build-up that depends entirely on a layer of rigid, abutting insulation board, a timber frame solution to the inner leaf would provide two layers of insulation. It may be possible to use the continuous sheet of mineral wool as a complete cavity fill solution. This would, if deemed appropriate, de-risk the construction process in terms of thermal integrity.

The third thermal bridge is produced because the window is located in line with the external, uninsulated masonry leaf. This produces a 'kink'. To remove this thermal bridge, it may be better to pull the window line inwards so that it aligns with the cavity zone. This would provide a consistent and unbroken thermal line. Pressure on detailing and construction would be thus reduced. This solution is more effective if, as above, it is paired with a timber frame inner leaf instead of a masonry leaf design. This would provide more options for supporting and fixing this frame using a timber framing solution.

The thermal bridge to the roof zone could be removed by introducing a continuous and unbroken thermal layer below the roof joists. This may be achieved by bonding rigid or semi-rigid insulation to a carrier board below the joists before finishing with plasterboard and 5mm skim.

Figure 5: mark up showing possible thermal bridging solutions in typical strip section

## Airtightness:

A continuous air-tight line to the inner side of the envelope helps retain warm, heated air within the building.

After examining the 6 section types, the research team identified several instances where this air-tightness line was broken.

1 The liquid poured screed in the designed floor-build up serves as an air-tightness line. For the wall, the design includes a plasterboard finish to the inner leaf. In this assessment it was assumed that this plasterboard was finished with 5mm plaster skim. This continuous skim serves as the air-tightness layer (note that block-work is air permeable and does not form an air-tight line). However, the junction between the wall and the floor produces a break in the air-tightness line. In this build-up, air can leak between the skirting board and the floor finish. At this point, it can take two paths. It can move through the perimeter insulation, the floor insulation, between the beam and block floor and into the floor void. Or it can leak through the block-work into the cavity and through the external leaf.

2 The second break in the air-tightness line occurs at the window head and base. At the base, air can escape below the sill board and around the window to the outside. At the base it can escape at the interface between the window and the plasterboard.

3 The third break in the air-tightness line occurs in the floor zone. The drawings show that the plasterboard and skim stops at ceiling level and floor level and there is nothing to suggest that the ceiling and floor is completely air-tight. This means that air can currently escape into the floor zone and then through the external envelope.

4 The fourth break in the air-tightness line will be produced from the subsequent design and installation of electrical servicing. In the current design, the architect has assumed that all electrical runs and sockets / light switches etc will be chased into the masonry wall. This chasing will accommodate the electrical cables and the back boxes. The problem is that all such chasing will break the airtightness line produced by the plaster skim. We do not know the extent of this chasing but we can fairly assume that it will be extensive.

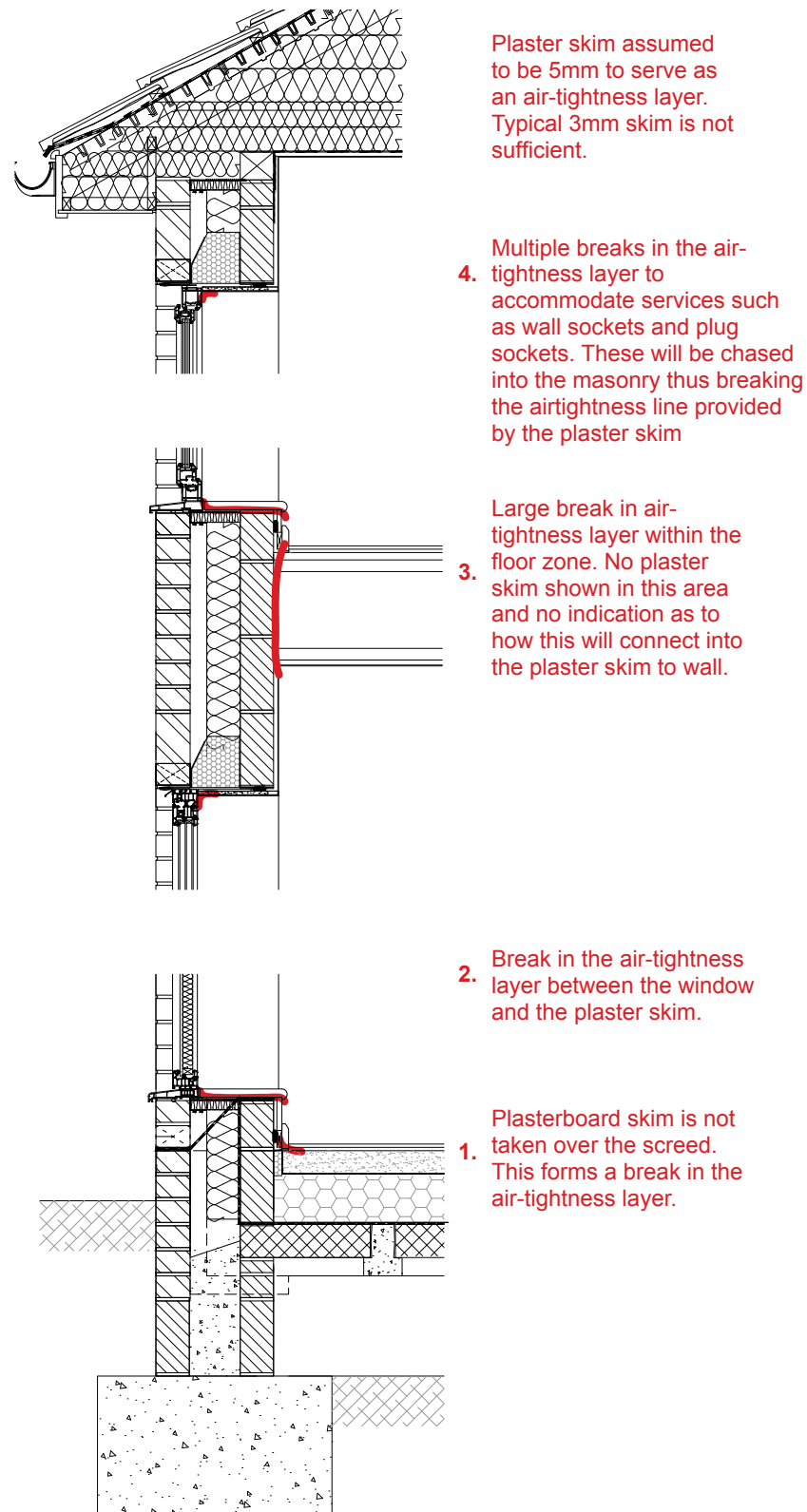
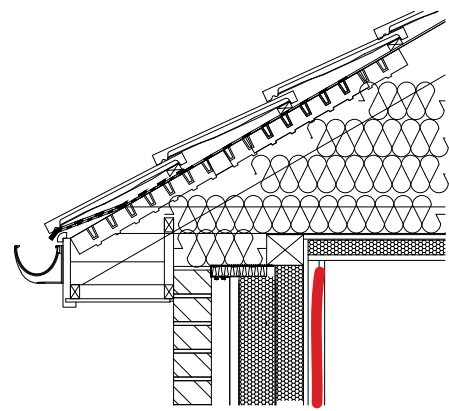
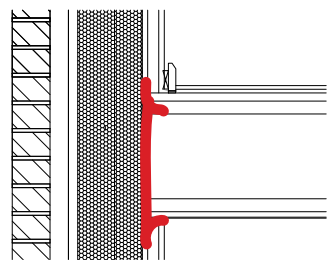

Figure 6: mark up showing air-tightness breaks in typical strip section





4. Add in a service zone



3. Extend air-tightness line through the floor zone and seal / tape to joists

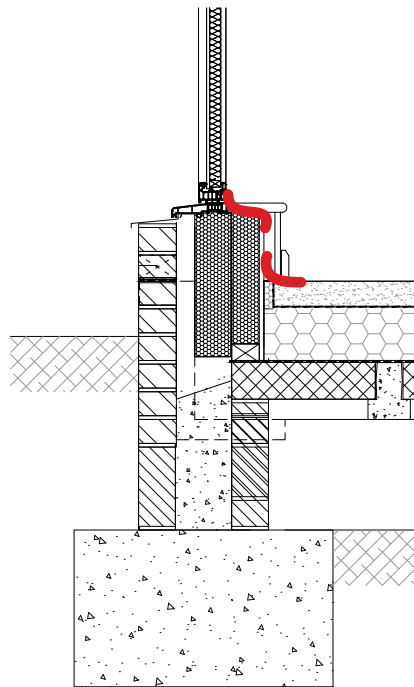

2. Air-tightness membrane and tape to window detail

1. Air-tightness membrane and tape

### How might we resolve these breaks in the air-tightness line?

Further design changes could be used to reduce air leakage in these locations. These options are identified below and presented in the marked-up drawing overleaf.

- 1 To remove air leakage at the junction between the floor and the wall, the wet plaster skim could be carried up to the junction with the floor. At this point, the design may incorporate a continuous ribbon of wet plaster at the interface. If this is not possible owing to the width of the perimeter insulation, it may be possible to introduce a thin strip of air-tight membrane lapped over the plaster skim and the floor finish sealed and jointed using air-tightness tape. The skirting would need to be located and positioned to cover this solution.
- 2 To remove the break in the air-tightness layer at the window base, the most appropriate solution might be to introduce a layer of air-tightness membrane below the sill board and then taped and jointed to the window frame and the plasterboard skim. Some concealing junction / detail will be needed to hide this tape (unless it is possible to skim over this tape). At the head, the plaster skim could be taken up to the window and the junction finished with air-tightness tape. Some concealing junction / detail will be needed to hide this.
- 3 The third break in air-tightness occurs in the floor zone. A simple solution to this would be to extend the plasterboard and skim within this zone between the joists and ensure that all joist-to-plaster interfaces are sealed using air-tightness tape.

Removing the fourth kind of break in the air-tightness line will have a greater impact on the design. Even if the masonry is exchanged for a timber frame solution as per the previous suggestions, it is not possible to locate services within the depth of the timbers without breaking or risking the air-tightness line. One simple way to resolve this is to introduce a service zone. This has several advantages. One advantage is that the air-tightness line could be achieved through a dry-installation solution instead of wet plaster skim. This could be a sheet or a specialist OSB board taped and sealed at all junctions. This would make overlapping details much simpler and improve construction times / programming. The service zone would be located outside of the air-tightness line and would be to a depth of approx. 30mm to accommodate the typical depth of electrical back boxes. This depth could be produced using a 30mm batten and then lined with plasterboard. Given that this internal finish is no longer acting as the air-tightness line, this plasterboard could be jointed rather than skimmed. This solution is, thus, much quicker, easier and less labour intensive. There would be an increase in the overall wall thickness to accommodate this service zone and would need to be costed accordingly.

Figure 7: mark up showing possible airtightness solutions in typical strip section

The aim of the first project stage was to review the operational energy, embodied carbon and plastic in a new-build housing type and identify opportunities for improvement.

This aim was achieved by:

- Identifying a 'typical' house-type used for new-build developments by YHG
- Assessing the envelope design of this 'typical' house-type in terms of operational energy
- Assessing the materials used in the design of this 'typical' house-type in terms of embodied carbon
- Assessing the materials used in the design of this 'typical' house-type in terms of embodied plastics
- Using this insight to identify opportunities for improving the design

### How to assess the embodied carbon of products used in the section types?

Embodied carbon relates to the quantity of carbon emissions released during the lifecycle of building materials. In other words, it relates to the building prior to and regardless of its use. These quantities do not only relate to the product, but also to the carbon released in extracting the materials that form it, the manufacturing of these materials, the transportation, and construction using these products.

How do we calculate embodied carbon?

The first step was to identify and record all data-sheets related to products used in the 6 sections. The research team used these to ensure that the products identified did not require other products for installation e.g., a suitable substrate.

Whilst data-sheets provide important information about the installation of a given product, they offer little insight into their embodied carbon values. This information is produced as part of an Environmental Product Declaration (EPD). Unfortunately, it is not mandatory for product manufacturers to produce an up-to-date EPD for all products in all of their product ranges. To date, many products including those specified do not have associated EPDs.

To overcome this limitation, the team used an EPD database to identify similar products and to use the embodied carbon data in these EPDs as a proxy for the actual product specified. This method introduces obvious limitations to the accuracy of any Embodied Carbon calculation. Products used as a proxy could be manufactured differently and composed of different materials, it could be produced in a different country with different regulations and norms. These limitations are inherent in all embodied carbon calculations used in the industry and thus reflects a wide-scale limitation that should be considered through future research. The results of this third step was a database of over 50 EPDs.

The next step was to interpret the embodied carbon values of these products as weight (Kg) of Co2 for an appropriate declared unit. These units are different for each product type. This unit may be a tonne, a 1m2 area, a 1 linear metre of material or a single unit. This data was calculated from these sheets and added to three of the 6 sections (to avoid repetition).

## How to assess the embodied plastics of products used in the baseline section?

The above text identifies some of the limitations associated with assessing the embodied carbon of building products.

Far more limitations are found in trying to assess embodied plastic content of the same products.

This is because these EPDs were not intended for this purpose. Whilst they identify materials used in the manufacturing process, such information is limited. As a consequence, we cannot provide a clear quantitative assessment of the plastic used in a product (plastic content) or in the manufacture of that product.

Taking account of this limitation, the research team decided to identify products according to a rough percentage of plastic content based on this data. The figures produced from this exercise are general approximations and presented as annotated sections.

<b>DAL'ALU</b> gutter A: 5 kgCo2 / 1LM B: 0%	<b>SAINT-GOBAIN</b> roof insulation A: 4.1 KgCo2 / 1m2 B: 99%	<b>Marley</b> roof tiles A: 0.273 KgCo2 / 1kg B: 0%	<b>Tyvek</b> roof membrane A: 4.1 KgCo2 / 1m2 B: 47%	<b>Manthorpe</b> Ventilation roll A: No data B: <99%	<b>KLOBER</b> over-fascia vent A: No data B: <99%	<b>pro climo</b> ceiling membrane A: 1.47KgCo2 / 1m2 B: >99%	<b>Wood Solutions</b> wall plate A: 199.9 KgCo2 / 1m3 B: 0%	<b>Freefoam</b> fascia & soffit A: No data B: 99%
---	--	--	---	---	--	---	--	--

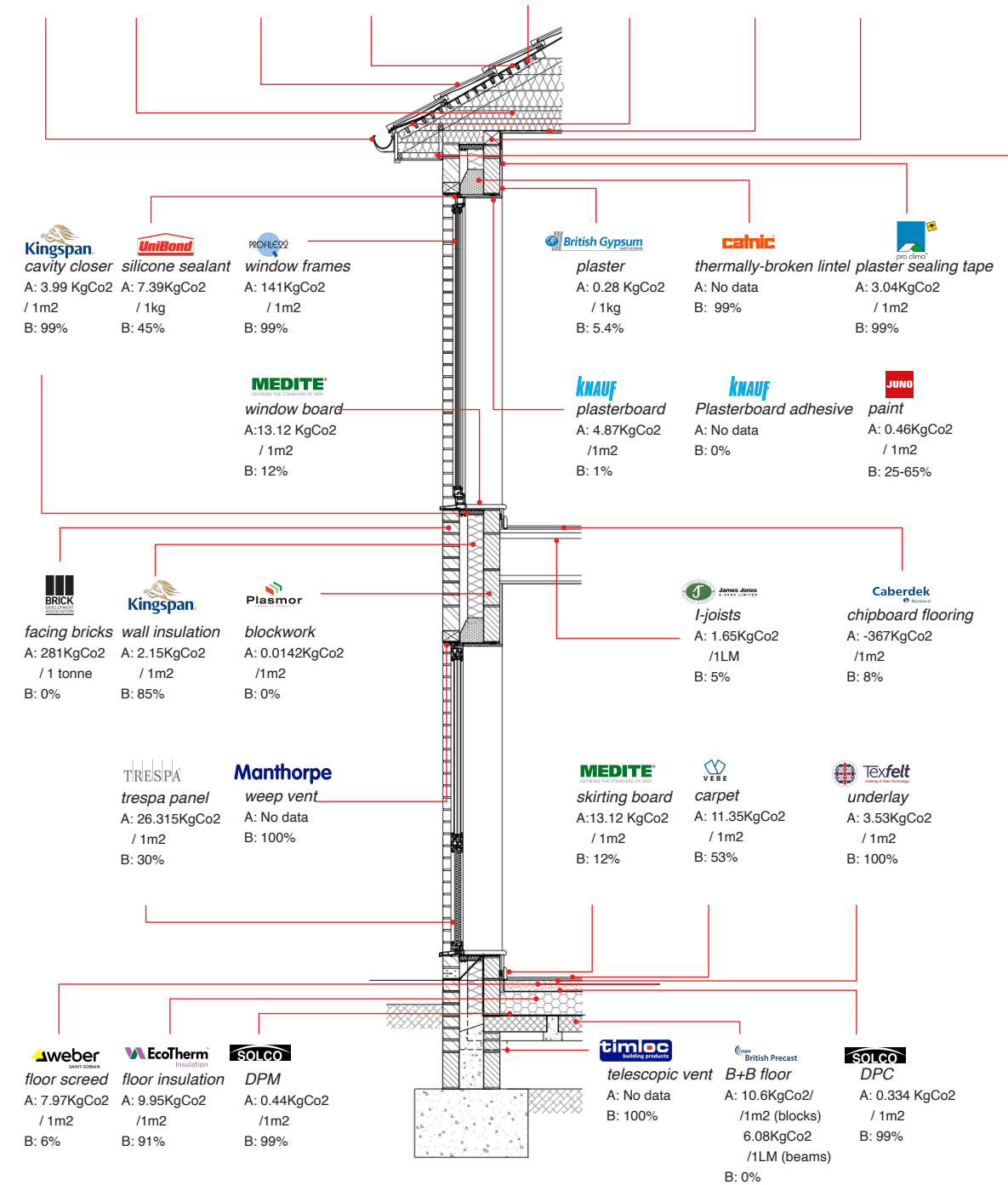

SECTION A-A

LEGEND

Figure 8: mark up showing embodied carbon and plastic in Section A-A  
A = embodied carbon  
B = % of plastic within element



<b>DAL'ALU</b>	<b>SAINT-GOBAIN</b>	<b>Marley</b>	<b>Tyvek</b>	<b>Manthorpe</b>	<b>KLOBER</b>	<b>pro clend</b>	<b>Wood Solutions</b>
<b>gutter</b>	<b>roof insulation</b>	<b>roof tiles</b>	<b>roof membrane</b>	<b>Ventilation roll</b>	<b>over-fascia vent</b>	<b>ceiling membrane</b>	<b>wall plate</b>
A: 5 kgCo2	A: 4.1 KgCo2	A: 0.273 KgCo2	A: 4.1 KgCo2	A: No data	A: No data	A: 1.47KgCo2	A:199.9 KgCo2
/1LM	/ 1m2	/ 1kg	/ 1m2	B: 99%	B: 99%	/ 1m2	/ 1m3
B: 0%	B: 99%	B: 0%	B: 47%			B: 99%	B: 0%

<b>DAL'ALU</b>	<b>SAINT-GOBAIN</b>	<b>Marley</b>	<b>Tyvek</b>	<b>Manthorpe</b>	<b>KLOBER</b>	<b>pro clend</b>	<b>Wood Solutions</b>	<b>Freefoam</b>
<b>gutter</b>	<b>roof insulation</b>	<b>roof tiles</b>	<b>roof membrane</b>	<b>Ventilation roll</b>	<b>over-fascia vent</b>	<b>ceiling membrane</b>	<b>wall plate</b>	<b>fascia &amp; soffit</b>
A: 5 kgCo2	A: 4.1 KgCo2	A: 0.273 KgCo2	A: 4.1 KgCo2	A: No data	A: No data	A: 1.47KgCo2	A:199.9 KgCo2	A: No data
/1LM	/ 1m2	/ 1kg	/ 1m2	B: 99%	B: 99%	/ 1m2	/ 1m3	B: 99%
B: 0%	B: 99%	B: 0%	B: 47%			B: 99%	B: 0%	B: 99%

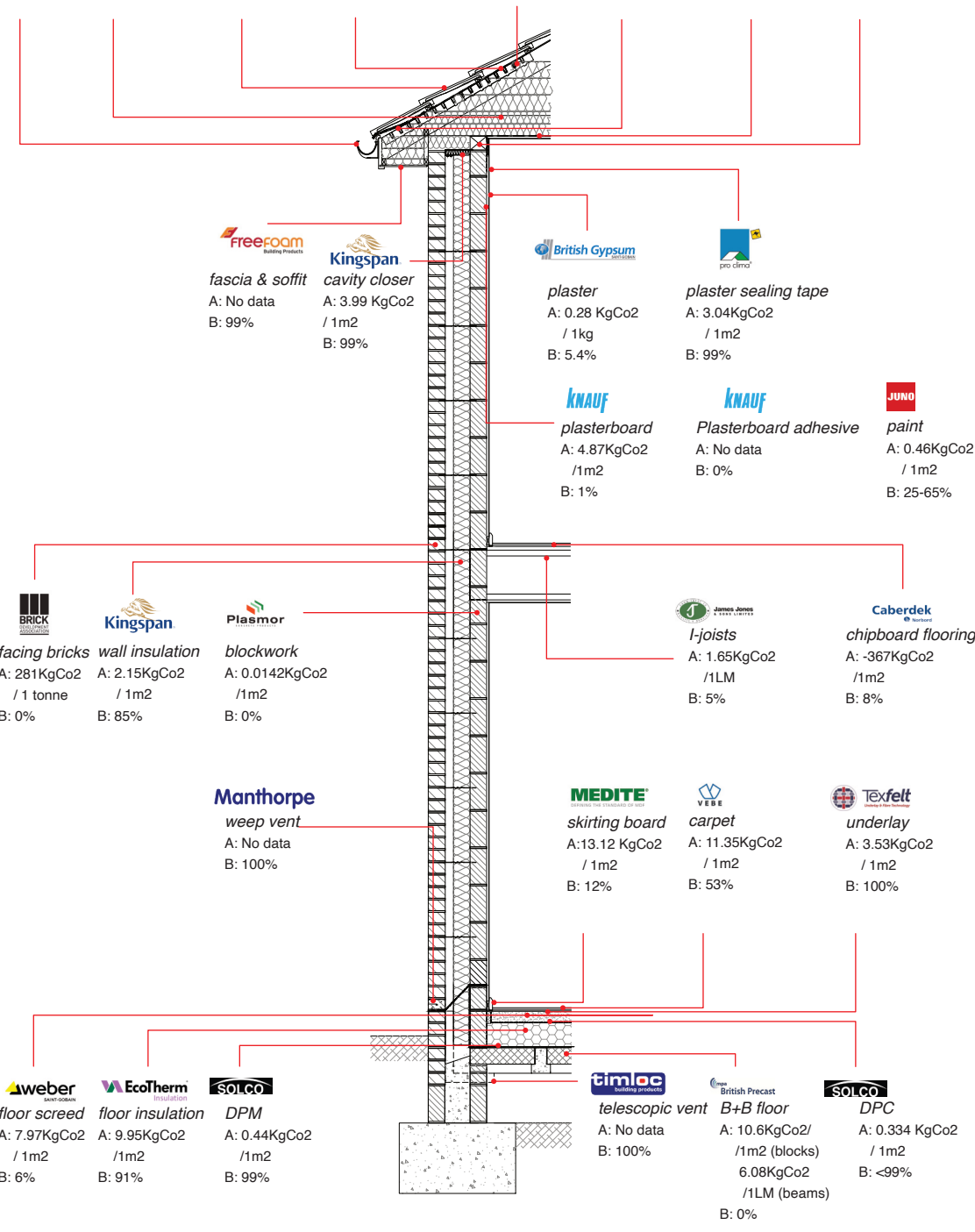

SECTION B-B

LEGEND

Figure 9: mark up showing embodied carbon and plastic in Section B-B

A = embodied carbon  
B = % of plastic within element

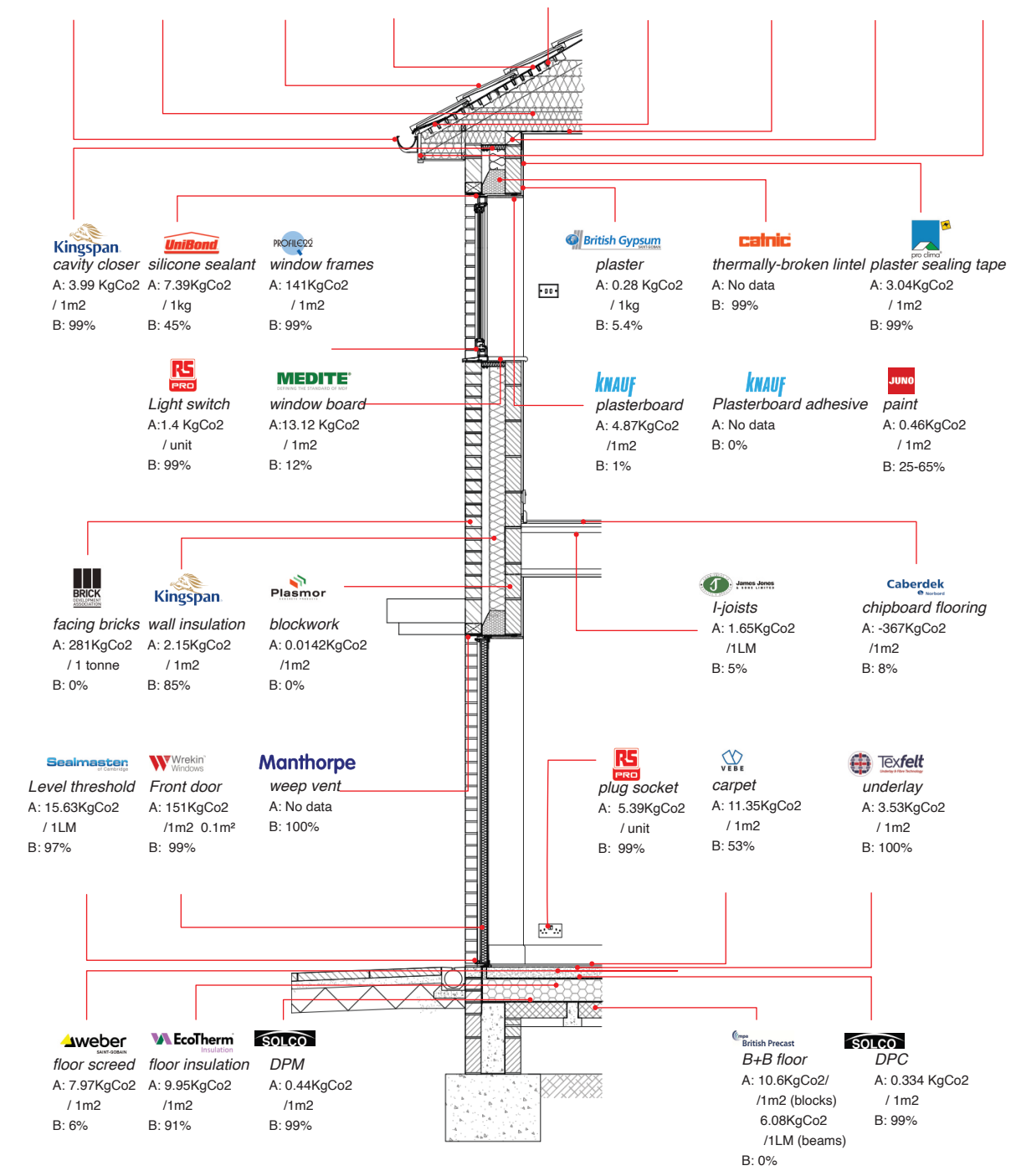

SECTION C - C

LEGEND

Figure 10: mark up showing embodied carbon and plastic in Section C-C

A = embodied carbon  
B = % of plastic within element

(i) What specific and general lessons can be learned from Part 1 of this study?

(ii) What are the next steps in the research?

Observation

*Methodology.* This study has provided a fresh and novel method for assessing operational energy, embodied carbon, and plastic on schemes where the information needed to form such assessments is incomplete. By focusing on sample sections of a standard depth, this method allows sections to be compared from case to case and for these insights to be applied to and to inform different cases.

Suggestion

This methodology could be expanded and refined through further research and case studies. This method could be used by YHG on all subsequent projects and integrated in their internal review processes. More generally, this could provide industry with a practical way to assess schemes at different points in the design process especially when all information is not available.

Observation

*Operational Energy.* The study identified 4 areas of partial thermal bridging in the envelope design for sections 1-6. It also identified 4 areas of the detailing where the air-tightness line had been broken. The study identified possible design options to (further) mitigate these instances of thermal bridging and breaks in air-tightness. This study is intended as a research project / assessment rather than as a design proposal / solution. However, this study shows that there are opportunities to improve the detailing of these sections to improve operational energy of the scheme.

Suggestion

This study suggests opportunities for assessing case studies according to thermal bridging and air-tightness as well as U-values. This could be used as a requirement in the ERs.

Observation

*Embodied carbon and plastic.* The study identifies the embodied carbon and plastic content for all specified products identified in strip sections of a 'typical' house-type.

Suggestion

Building on these findings, the study suggests that YHG should consider expanding their standard Employer Requirement documents to ensure all designs are assessed to identify thermal bridging, airtightness breaks, embodied carbon and plastic content.

Observation

*Embodied carbon and plastic.* The study identified the inherent difficulties in assessing embodied carbon and plastic content for different products. In terms of the former it reveals two limitations. The first relates to a wider industry limitation about the availability of EPDs for the products selected. Because of this limitation studies are based on proxies which may (or not) be relevant. The second relates to the use of different declared units that prevent comparison between products.

Suggestion

This study recommends several, general actions that could be taken by YHG to position itself as an industry leader in this area.

*Embodied carbon:* A wider research project is needed to understand the impacts of using proxies instead of specific products and to use these findings to identify find practical solutions. A similar research project is needed to identify a way to align different declared units to allow designers and assessors to directly compare the KgCo2 for all products.

For the latter, it shows that plastic content cannot be calculated accurately. Unlike embodied carbon we cannot identify the weight (Kg) of plastic used in each product.

*Plastic content:* One possible study may consider opportunities for integrating more detailed data on plastic content within the EPD process.

## Part 2: Existing housing stock

### Improving the energy performance of existing housing stock.

The aim of the second project stage was to review existing housing stock and identify opportunities to improve energy performance and to reduce fuel poverty.

This aim was achieved by:

- Reviewing a database of over 22k units to identify a sample
- Establishing a typology of typical assemblies and junctions (wall-to-floor, wall, wall-to-roof) relevant to these house-types
- Reviewing the operational energy (u values) of these typical assemblies and limitations in their design
- Expanding this database to include EPD data
- Using this data to identify issues associated with energy use and fuel poverty
- Identifying opportunities / strategies for improvement

### A revised scope of work

The contracted scope of works for Part 2 of the study was originally developed to mirror Part 1. The intention was to identify a base-line house type that could be studied as a new-build scheme (Part 1) and as an existing house to be upgraded to meet higher sustainability standards (Part 2). By focusing on the same house-type as new-build and existing / refurbishment, the study had aimed to demonstrate the different approaches required, as well as transferrable lessons / insights.

During the exploration phase of the study (1-3 months) the research team met with key YHG staff responsible for the maintenance of existing housing stock. These meetings were intended to ascertain a suitable site and house-type to serve as the baseline for the audit. From these meetings, it was agreed that this original strategy would not have the impact required. This is because YHG's portfolio of existing stock is highly varied. Whilst it does include a number of house-types built on several sites (including House-type 87), this represents a small percentage of the total stock profile. With this in mind, the project team agreed to develop a revised approach to Part 2 that would better reflect this profile and with greater potential for impact.

Given the size of this portfolio (over 22k units) and the diversity of this portfolio, this revised scope was developed and refined during the exploration stage (months 1-3).

From this, the team established the the six stages of work for Part 2 as noted overleaf.

## Improving the energy performance of existing housing stock.

The aim of the second project stage was to review existing housing stock and identify opportunities to improve energy performance and to reduce fuel poverty.

This aim was achieved by:

- Reviewing a database of over 22k units to identify sample
- Establishing a typology of typical assemblies and junctions (wall-to-floor, wall, wall-to-roof) relevant to these house-types
- Reviewing the operational energy (u values) of these typical assemblies and limitations in their design
- Expanding this database to include EPC data
- Using this data to identify issues associated with energy use and fuel poverty
- Identifying opportunities / strategies for improvement

## Producing a sample from a database of 22k units

The database provided by YHG includes 22,880 units in total.

It is beyond the scope of this study to cover all units in this large dataset. To identify a sample for the study, the research team categorised the data by focusing on specific traits. By selecting the largest grouping/s within these categories, the team were able to identify a sample that would be representative of / the greatest potential for impacting the overall stock profile.

This selection process was directed by three logical themes:

- Unit type
- Construction type
- Availability of Energy Performance Certificate (EPC) data

Bedsit	466
Flats	9878
Maisonette	152
Bungalow	2188
House	10196

Table 1: Unit type of existing stock

Blank:	777
Non-Traditional:	301
Non-Traditional – timber frame:	99 (6 sites)
Traditional- solid:	105
Traditional:	5139
Traditional cavity wall:	3775

Table 2: construction type of existing housing stock

Traditional- solid:	80
Traditional:	4532
Traditional cavity wall:	3206

Table 3: construction type of existing housing stock allowing for EPC data

## Stage 1: Producing a sample

### Unit type

The first category focused on a distinction in the data between houses, bungalows, rooms and flats. To help reduce the sample size, the research team decided to focus on the former. This decision was made for several reasons.

*Discounting flats and rooms:* The decision to exclude rooms and flats from the study was made to reduce the complexity of the cases included in the sample (complexity that is not identifiable within the dataset or currently available from other sources). Flats and rooms refer to internal spaces or sub-divisions of a building. These sub-divisions can vary for each instance. It is highly likely that a flat will be part of a larger building with shared walls, floors, and roofs. Refurbishment of such units to a higher sustainability standard will vary on a case-by-case basis and should form the focus of future research. Flats and rooms were thus discarded from the sample.

*Discounting bungalows:* Whilst bungalows and houses share a great deal in common, the most important distinction lies in the ratio between footprint and gross internal area. Bungalows require different design solutions to accommodate heat loss. For the purposes of assessment and subsequent refurbishment works, they should be treated separately.

Sample of 10,196 houses.

### Construction type

The second category focused on the construction type of houses in the sample. The dataset could be grouped into traditional and non-traditional construction methods. Unclassified units were discounted for the purpose of the study.

As the table shows, of the 10,196 units in the sample, 9,419 units were classified. Of these, 9,019 were classified as traditional construction.

This same proportion is reflected in the total stock profile. Of the 20,032 classified units (houses, rooms and flats), 19,234 units, representing 96% of housing stock were classified as traditional. This suggests that some of the insights from a study of houses may be transferable to a more complex sample that includes all housing stock.

NB / a review of EPC data for stock identified as 'traditional' showed that these are also traditional cavity construction and will be treated as such in the sample.

Sample of 9,019 units

### Availability of EPC data

Not all houses within this sample have an up-to-date EPC certificate. The EPC certification scheme provides data on all assessed units. Given that YHG do not have an accurate and detailed breakdown of all units in their portfolio in terms of their construction, M+E equipment, upgrades etc, this EPC data is fundamental to understanding the performance of the stock as a whole. On this basis, only units with a valid EPC certificate were included.

Of the 9,019 units identified so far, 7,818 have EPC certificates (86.7%).

Sample of 7,818 units

This refined sample of 7,818 units was identified as the focus of the study. This sample accounts for 77% of all existing housing stock, and 34% of *all* YHG stock.

## Improving the energy performance of existing housing stock.

The aim of the second project stage was to review existing housing stock and identify opportunities to improve energy performance and to reduce fuel poverty.

This aim was achieved by:

- Reviewing a database of over 22k units to identify baseline typology of house types
- Establishing a typology of typical assemblies and junctions (wall-to-floor, wall, wall-to-roof) relevant to these house-types
- Reviewing the operational energy (u values) of these typical assemblies and limitations in their design
- Expanding this database to include EPD data
- Using this data to identify issues associated with energy use and fuel poverty
- Identifying opportunities / strategies for improvement

### Establishing typologies within this sample

From this refined sample, the team grouped the data by year according to key periods in history. These reflected changes in the typical detailing used, construction technology and regulation of housing in the UK.



## Stage 2: Establishing typologies within the sample

All 7,818 units in the sample from Stage 1 are identified as traditional construction. But the nature of this traditional construction differs within this sample. One such differentiation is between a cavity and solid construction. The dataset refers to wall construction, but this same distinction equally applies to floors.

Within these two categories we also know that cavity walls for example are not always built in the same way. This is because the build-up of materials in a 'traditional cavity wall' will change over time. A cavity wall in the year 1900 will be very different to a cavity wall in 2000 for example.

This distinction is fundamental because it means that walls will perform very differently in terms of heat retention when built at different periods of time. This observation is particularly relevant to YHG's housing stock.

Like many housing associations, YHG have acquired many different buildings over time. The largest quantity of these units was not purpose-built as affordable housing units and were not built by YHG. As a consequence, YHG's stock covers a wide range of building periods. The earliest building in this selected sample was built in 1851, whilst the latest was built 2016. This represents a period of 165 years.

Over this period there has been considerable changes in the construction industry, not least the introduction and refinement of building regulations (Part L as relevant to this study).

With this in mind, the research team decided that the most logical typologies to be used in subsequent studies and in refurbishment strategies by YHG should be based on different kinds of construction assembly relevant to key periods in time.

### *Historical study and extending the categories*

The research team undertook an extensive historical study of typical construction methods and build-ups used in residential schemes over this period between 1851 and 2016. From this research, the team identified six key stages:

- i. Pre-1918
- ii. 1918-1944
- iii. 1945-1959
- iv. 1960-1979
- v. 1980-1993
- vi. 1994-2022

In each of these periods, we can identify fundamental changes in the design of the three key assemblies of a house:

- 1. roof,
- 2. walls
- 3. floors.

These historical categories could then be combined with the categories identified in the data

- 1. traditional cavity (also referred to as traditional)
- 2. traditional solid construction

Based on this historical research, the team produced typical details for each of these categories.

Total stock within sample (7,818)			
Ref code	Description	No. of YHG stock	% stock
i.1.1	Pre-1918 solid wall	554	7
i.1.2	Pre-1918 cavity wall	209	2.7
ii.1.1	1918-1944 solid wall	960	12.27
ii.1.2	1918-1944 cavity wall	113	1.4
iii.1.1	1945-1959 solid wall	0	0
iii.1.2	1945-1959 cavity wall	1091	13.95
iv.1.1	1960-1979 solid wall	10	0.13
iv.1.2	1960-1979 cavity wall	1415	18
v.1.1	1980-1993 solid wall	15	0.19
v.1.2	1980-1993 cavity wall	1388	17.75
vi.1.1	1994-2022 solid wall	0	0
vi.1.2	1994-2022 cavity wall	2063	26.39

Table 4: typology types and number of stock



# Assemblies- Walls

# Assemblies- Walls

Pre 1918

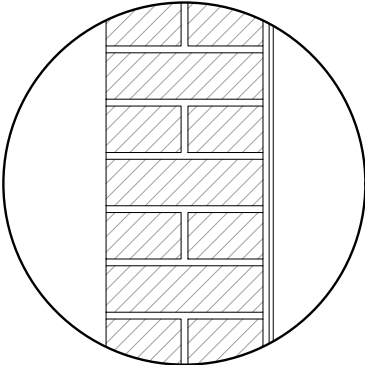

i.1.1

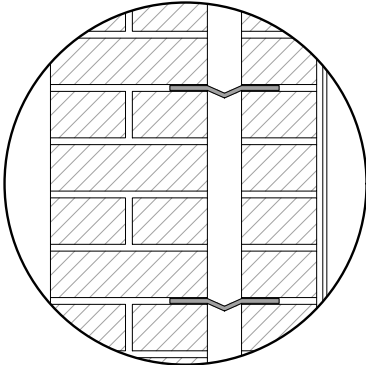

i.1.2

1918 - 1944

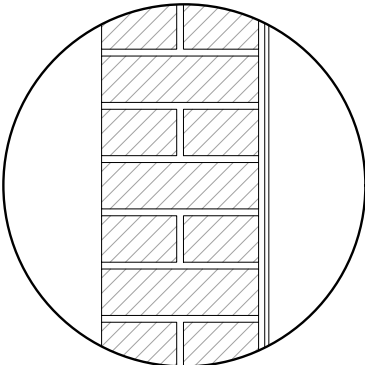

ii.1.1

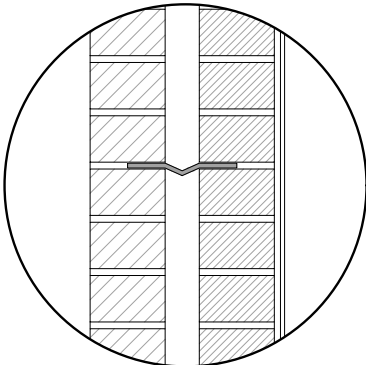

ii.1.2

1945 - 1959

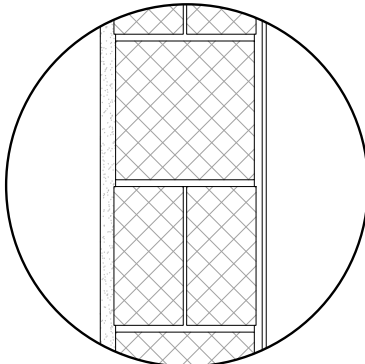

iii.1.1

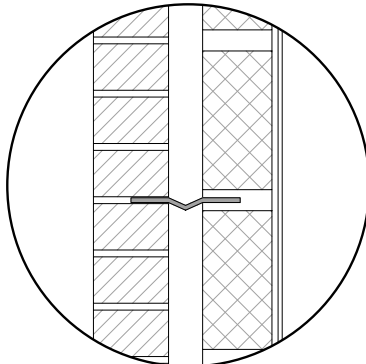

iii.1.2

1960 - 1979

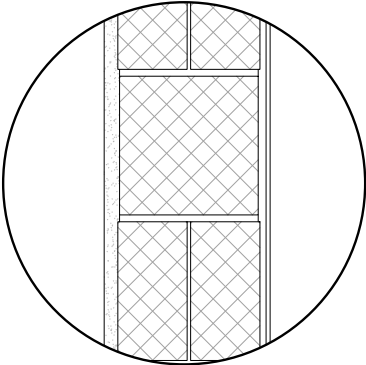

iv.1.1

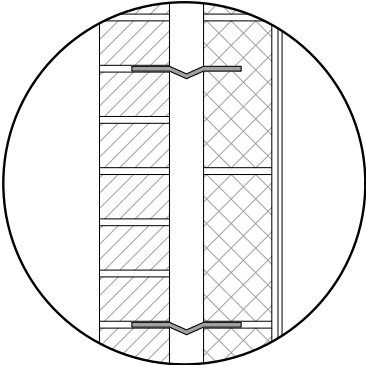

iv.1.2

1980 - 1993

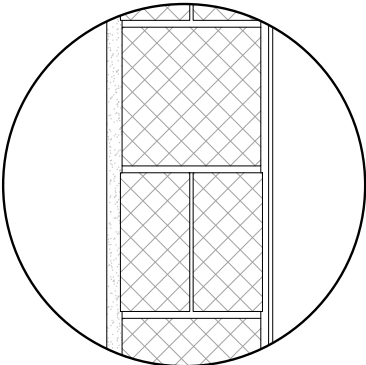

v.1.1

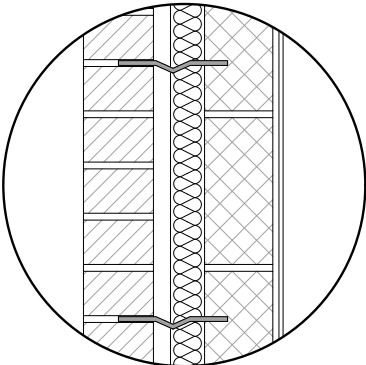

v.1.2

1994 - 2022

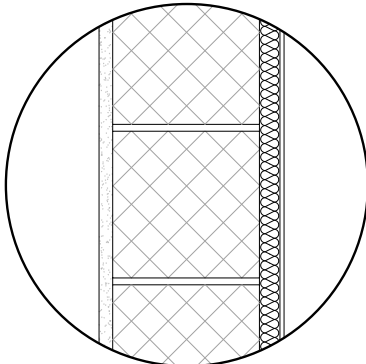

vi.1.1

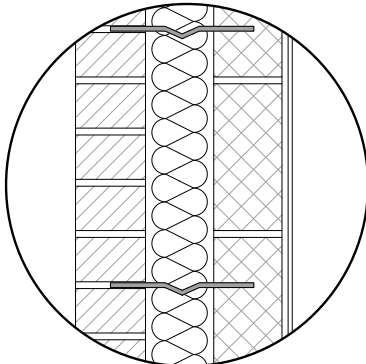

vi.1.2

Figure 11: assembly typologies

Figure 12: assembly typologies

# Assemblies - Floors

Pre 1918

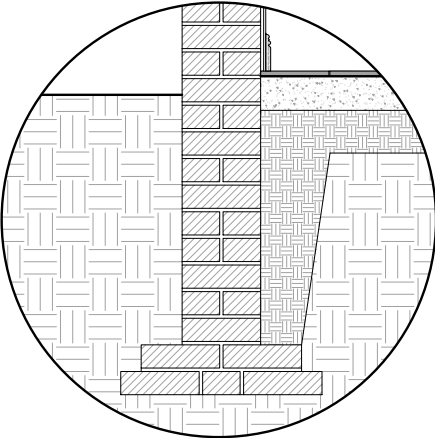

i.2.1

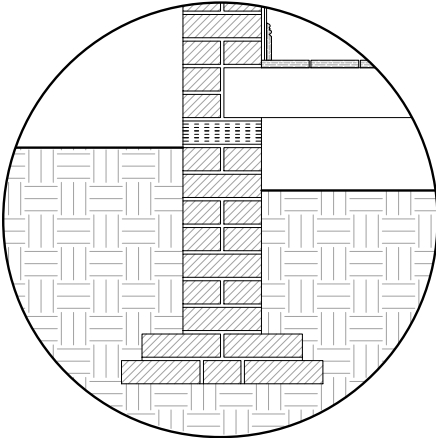

i.2.2

1918 - 1944

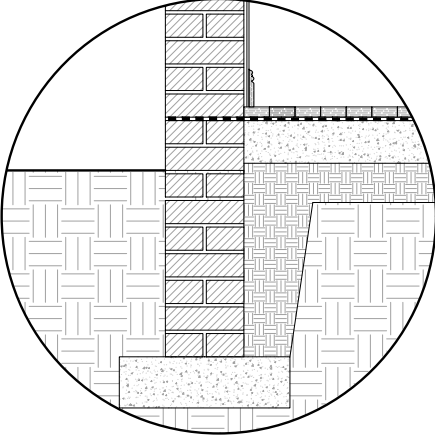

ii.2.1

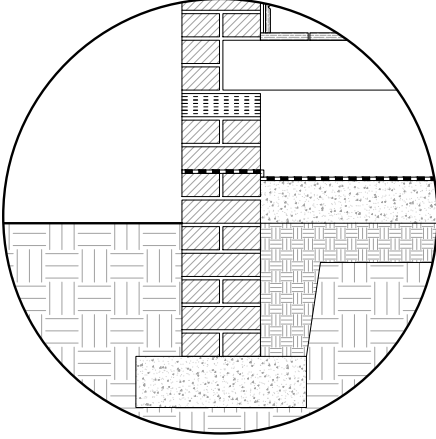

ii.2.2

1945 - 1959

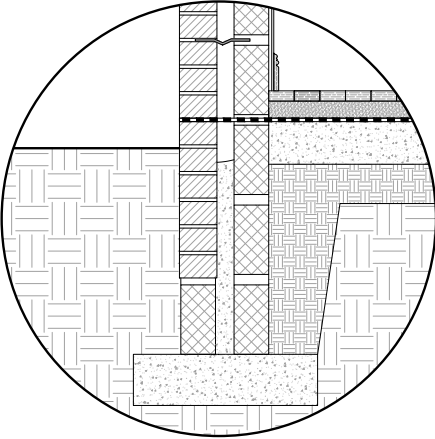

iii.2.1

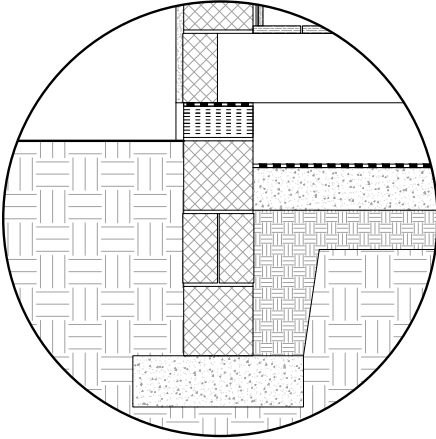

iii.2.2

Figure 13: assembly typologies

# Assemblies - Floors

1960 - 1979

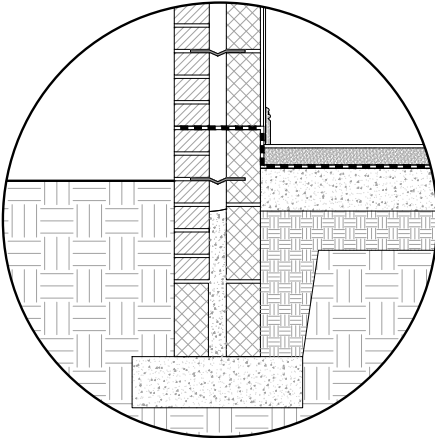

iv.2.1

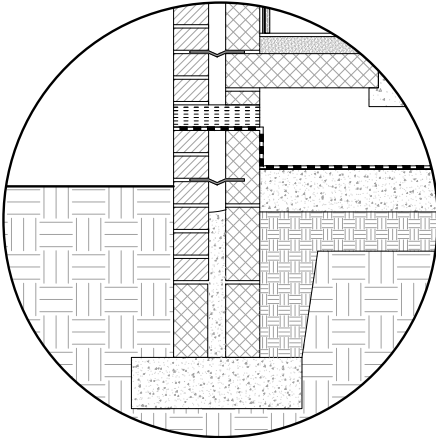

iv.2.2

1980 - 1993

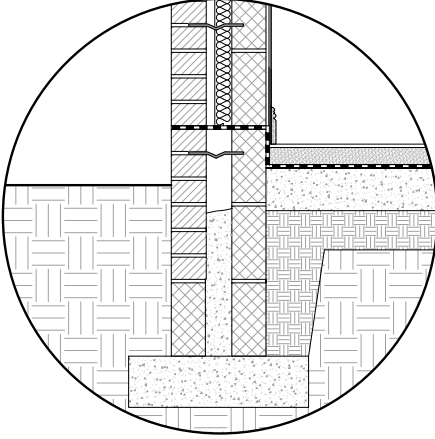

v.2.1

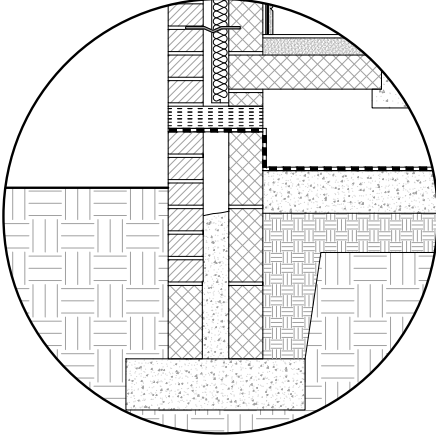

v.2.2

1994 - 2022

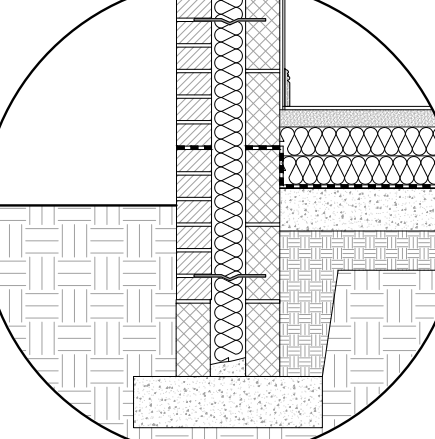

vi.2.1

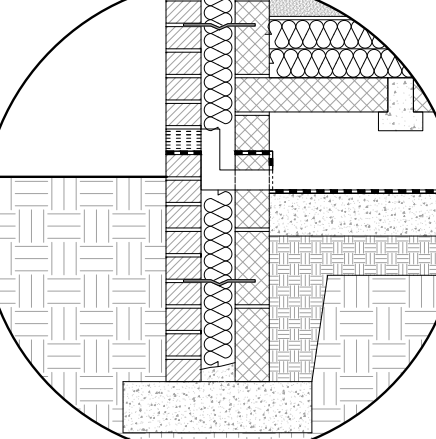

vi.2.2

Figure 14: assembly typologies

# Assemblies - Roofs

Pre 1918

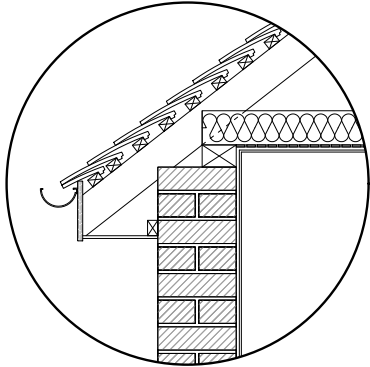

i.3

1918 - 1944

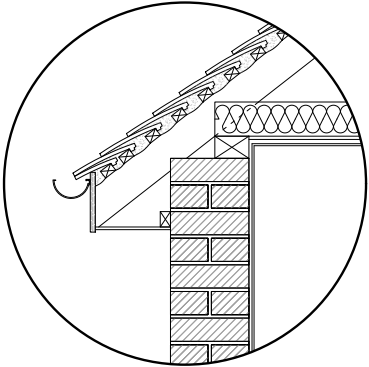

ii.3

1945 - 1960

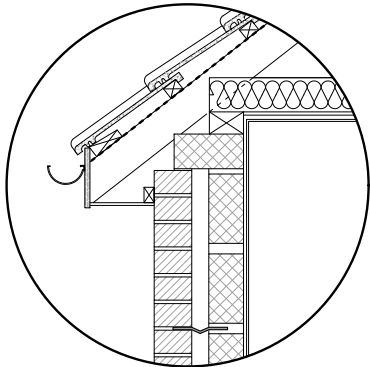

iii.3

1960 - 1979

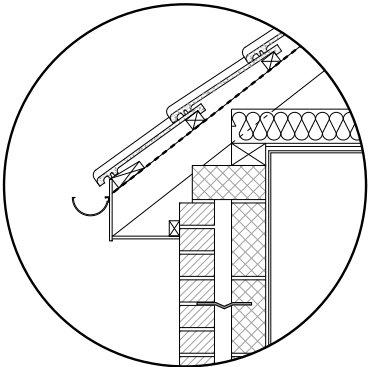

iv.3

1980 - 1993

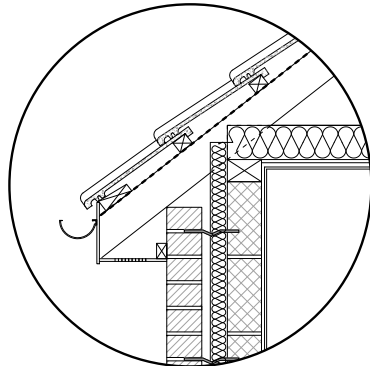

v.3

1994 - 2022

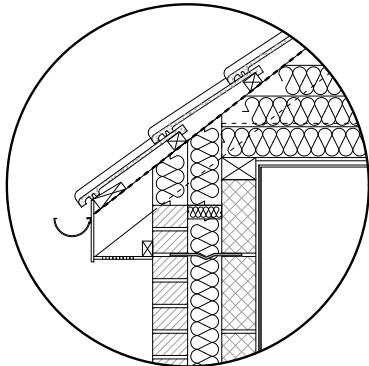

vi.3

Figure 15: assembly typologies

## Improving the energy performance of existing housing stock.

The aim of the second project stage was to review existing housing stock and identify opportunities to improve energy performance and to reduce fuel poverty.

This aim was achieved by:

- Reviewing a database of over 22k units to identify baseline typology of house-types
- Establishing a typology of typical assemblies and junctions (wall-to-floor, wall, wall-to-roof) relevant to these house-types
- Reviewing the operational energy (u values) of these typical assemblies and limitations in their design
- Expanding this database to include EPC data
- Using this data to identify issues associated with energy use and fuel poverty
- Identifying opportunities / strategies for improvement

### Stage 3: Operational energy

Given the different construction details used in each assembly, the next stage of the research was used to:

- Establish the thermal performance for each assembly
- Consider these against two targets: the equivalent of EPC level C and effective carbon zero envelope design.

#### ■ Thermal performance of assemblies

To establish U values, the research team produced a thermal model for each of the assemblies presented in the last section.

#### Establishing targets

##### ■ **EPC C**

EPC level C was identified as one of the targets for refurbishment. This target relates to a national agenda for improving housing stock in the UK. It is also identified within the industry as a minimum thermal standard prior to the installation of sustainable technologies such as heat pumps and solar panels.

##### ***Fabric focused targets***

The second target for thermal values of the envelope (U-values) is derived from the Passive House standard.

## Thermal performance of assemblies

To develop a thermal model for each assembly, the team undertook more detailed research into the likely dimensions and thermal conductivity for all materials / products used in all assemblies.

### Assemblies pre-1918 to 1993

For assemblies built between pre-1918 and 1993, this information on thermal conductivity and dimensions was added to a thermal model and used to general U-values.

### Assemblies 1993-2022

For assemblies produced after this period, the research team needed to introduce another layer of research. This marks the point when all assemblies included thermal insulation, which was sized to meet target thermal values defined in Part L of the Building Regulations.

It was assumed that all building stock within the YHG portfolio meets the building regulation criteria specific to the date of its construction (neither under-performing nor exceeding this requirement). This criteria could then be used to calculate insulation thickness by 'reverse engineering' the designs.

Actual component U values							
Period	Walls (solid)	Walls (cavity)	Floors (on ground)	Floors (suspended)	Roof	Windows	Doors
Pre 1918	1.823 W/m2/K	1.375 W/m2/K	3.977 W/m2/K	2.196 W/m2/K	0.31 W/m2/K	3.3 W/m2/K	3.3 W/m2/K
1918-1939	1.823 W/m2/K	1.779 W/m2/K	4.142 W/m2/K	2.196 W/m2/K	0.31 W/m2/K	3.3 W/m2/K	3.3 W/m2/K
1945-1959	1.485 W/m2/K	1.723 W/m2/K	3.339 W/m2/K	2.196 W/m2/K	0.31 W/m2/K	3.3 W/m2/K	3.3 W/m2/K
1960-1979	1.485 W/m2/K	1.723 W/m2/K	3.339 W/m2/K	1.442 W/m2/K	0.31 W/m2/K	3.3 W/m2/K	3.3 W/m2/K
1980-1993	1.485 W/m2/K	0.477 W/m2/K	3.339 W/m2/K	1.442 W/m2/K	0.31 W/m2/K	3.3 W/m2/K	3.3 W/m2/K

Table 5: thermal performance of assemblies

Actual component U values							
Period	Walls (solid)	Walls (cavity)	Floors (on ground)	Floors (suspended)	Roof	Windows	Doors
1994/5-2006	0.45 W/m2/K	0.45 W/m2/K	0.45 W/m2/K	0.45 W/m2/K	0.25 W/m2/K	3.3 W/m2/K	3.3 W/m2/K
2006-2010	0.35 W/m2/K	0.35 W/m2/K	0.25 W/m2/K	0.25 W/m2/K	0.25 W/m2/K	2.2 W/m2/K	2.2 W/m2/K
2010-2021	0.3 W/m2/K	0.3 W/m2/K	0.25 W/m2/K	0.25 W/m2/K	0.2 W/m2/K	2 W/m2/K	2 W/m2/K
2021-present	1.485 W/m2/K	1.723 W/m2/K	3.339 W/m2/K	1.442 W/m2/K	0.31 W/m2/K	3.3 W/m2/K	3.3 W/m2/K

Table 6: thermal performance of assemblies

Components U Values					
Building regulation Part L	Walls	Floors	Roof	Windows	Doors
1995 (effective 1995)	0.45 W/m2/K	0.45 W/m2/K	0.25 W/m2/K	3.3 W/m2/K	3.3 W/m2/K
2002 bregs (effective 2006)	0.35 W/m2/K	0.25 W/m2/K	0.25 W/m2/K	2.2 W/m2/K	2.2 W/m2/K
2010 (effective 2010)	0.3 W/m2/K	0.25 W/m2/K	0.2 W/m2/K	2.0 W/m2/K	2.0 W/m2/K
2010-2021	0.3 W/m2/K	0.25 W/m2/K	0.2 W/m2/K	2 W/m2/K	2 W/m2/K
2021- present	0.26 W/m2/K	0.18 W/m2/K	0.16 W/m2/K	1.6 W/m2/K	1.6 W/m2/K
2021- present refurb	0.55-0.7 W/m2/K	0.25-0.70 W/m2/K	0.16-0.35 W/m2/K	1.4 W/m2/K	1.4 W/m2/K

Table 7: thermal performance (U values) as stated in Building regulations Part L

Period	Actual and targets	Component U values						
		Walls (solid)	Walls (cavity)	Floors (on ground)	Floors (suspended)	Roof	Windows	Doors
Pre 1918	Actual	1.823 W/m2/K	1.375 W/m2/K	3.977 W/m2/K	2.196 W/m2/K	0.31 W/m2/K	3.3 W/m2/K	3.3 W/m2/K
	EPC C	0.3 W/m2/K	0.3 W/m2/K	0.25 W/m2/K	0.25 W/m2/K	0.2 W/m2/K	2.0 W/m2/K	2.0 W/m2/K
	Fabric	0.15 W/m2/K	0.15 W/m2/K	0.15 W/m2/K	0.15 W/m2/K	0.15 W/m2/K	0.8 W/m2/K	0.8 W/m2/K
1918-1939	Actual	1.823 W/m2/K	1.779 W/m2/K	4.142 W/m2/K	2.196 W/m2/K	0.31 W/m2/K	3.3 W/m2/K	3.3 W/m2/K
	EPC C	0.3 W/m2/K	0.3 W/m2/K	0.25 W/m2/K	0.25 W/m2/K	0.2 W/m2/K	2.0 W/m2/K	2.0 W/m2/K
	Fabric	0.15 W/m2/K	0.15 W/m2/K	0.15 W/m2/K	0.15 W/m2/K	0.15 W/m2/K	0.8 W/m2/K	0.8 W/m2/K
1945-1959	Actual	1.485 W/m2/K	1.723 W/m2/K	3.339 W/m2/K	2.196 W/m2/K	0.31 W/m2/K	3.3 W/m2/K	3.3 W/m2/K
	EPC C	0.3 W/m2/K	0.3 W/m2/K	0.25 W/m2/K	0.25 W/m2/K	0.2 W/m2/K	2.0 W/m2/K	2.0 W/m2/K
	Fabric	0.15 W/m2/K	0.15 W/m2/K	0.15 W/m2/K	0.15 W/m2/K	0.15 W/m2/K	0.8 W/m2/K	0.8 W/m2/K
1960-1979	Actual	1.485 W/m2/K	1.723 W/m2/K	3.339 W/m2/K	1.442 W/m2/K	0.31 W/m2/K	3.3 W/m2/K	3.3 W/m2/K
	EPC C	0.3 W/m2/K	0.3 W/m2/K	0.25 W/m2/K	0.25 W/m2/K	0.2 W/m2/K	2.0 W/m2/K	2.0 W/m2/K
	Fabric	0.15 W/m2/K	0.15 W/m2/K	0.15 W/m2/K	0.15 W/m2/K	0.15 W/m2/K	0.8 W/m2/K	0.8 W/m2/K
1980-1993	Actual	1.485 W/m2/K	0.477 W/m2/K	3.339 W/m2/K	1.442 W/m2/K	0.31 W/m2/K	3.3 W/m2/K	3.3 W/m2/K
	EPC C	0.3 W/m2/K	0.3 W/m2/K	0.25 W/m2/K	0.25 W/m2/K	0.2 W/m2/K	2.0 W/m2/K	2.0 W/m2/K
	Fabric	0.15 W/m2/K	0.15 W/m2/K	0.15 W/m2/K	0.15 W/m2/K	0.15 W/m2/K	0.8 W/m2/K	0.8 W/m2/K

Table 7: thermal performance of assemblies

Period	Actual and targets	Actual component U values						
		Walls (solid)	Walls (cavity)	Floors (on ground)	Floors (suspended)	Roof	Windows	Doors
1994/5-2006	Actual	0.45 W/m2/K	0.45 W/m2/K	0.45 W/m2/K	0.45 W/m2/K	0.25 W/m2/K	3.3 W/m2/K	3.3 W/m2/K
	EPC C	0.3 W/m2/K	0.3 W/m2/K	0.25 W/m2/K	0.25 W/m2/K	0.2 W/m2/K	2.0 W/m2/K	2.0 W/m2/K
	Fabric	0.15 W/m2/K	0.15 W/m2/K	0.15 W/m2/K	0.15 W/m2/K	0.15 W/m2/K	0.8 W/m2/K	0.8 W/m2/K
2006-2010	Actual	0.35 W/m2/K	0.35 W/m2/K	0.25 W/m2/K	0.25 W/m2/K	0.25 W/m2/K	2.2 W/m2/K	2.2 W/m2/K
	EPC C	0.3 W/m2/K	0.3 W/m2/K	0.25 W/m2/K	0.25 W/m2/K	0.2 W/m2/K	2.0 W/m2/K	2.0 W/m2/K
	Fabric	0.15 W/m2/K	0.15 W/m2/K	0.15 W/m2/K	0.15 W/m2/K	0.15 W/m2/K	0.8 W/m2/K	0.8 W/m2/K
2010-2021	Actual	0.3 W/m2/K	0.3 W/m2/K	0.25 W/m2/K	0.25 W/m2/K	0.2 W/m2/K	2 W/m2/K	2 W/m2/K
	EPC C	0.3 W/m2/K	0.3 W/m2/K	0.25 W/m2/K	0.25 W/m2/K	0.2 W/m2/K	2.0 W/m2/K	2.0 W/m2/K
	Fabric	0.15 W/m2/K	0.15 W/m2/K	0.15 W/m2/K	0.15 W/m2/K	0.15 W/m2/K	0.8 W/m2/K	0.8 W/m2/K
2021-present	Actual	1.485 W/m2/K	1.723 W/m2/K	3.339 W/m2/K	1.442 W/m2/K	0.31 W/m2/K	3.3 W/m2/K	3.3 W/m2/K
	EPC C	0.3 W/m2/K	0.3 W/m2/K	0.25 W/m2/K	0.25 W/m2/K	0.2 W/m2/K	2.0 W/m2/K	2.0 W/m2/K
	Fabric	0.15 W/m2/K	0.15 W/m2/K	0.15 W/m2/K	0.15 W/m2/K	0.15 W/m2/K	0.8 W/m2/K	0.8 W/m2/K

Table 8: thermal performance of assemblies

## EPC C target

A recent study by the Office for National Statistics (ONS, 2022) suggested that houses built pre-1900 to 1929 were just as likely to be below EPC C. Houses built 1983-2011 were slightly more likely to achieve this level, but houses built 2012 onwards are 200 times more likely to meet EPC C or better. These findings reflect the introduction and revisions to Part L of the Building Regulations. These performance requirements were introduced in Part L: 1995 and were increased through subsequent iterations in 2002, 2010 and 2021 (2013 iteration did not change these requirements).

On this basis it is fair to assume that U-values from the Part L: 2010 should be used as a target to upgrade building fabric for all houses built prior to 2012 to meet EPC C.

## Fabric focused targets

The second target can be loosely identified as 'fabric first'. This target places far greater emphasis on the thermal performance of the envelope, and less emphasis on technologies like heat pumps and solar panels. Whilst such technologies are still needed to achieve carbon zero, it would allow for more modestly sized units and panels.

This second target was derived from the Passive house Standard. This Passive house standard identifies U-values for all key assemblies, but it is not limited to these U-values. To fully meet this standard, individual house designs would need to be modelled in full (including M+E design) and adapted accordingly. This is beyond the scope of this study. The intention, therefore, was to use indicative U-values from the Passive house standard as a first step in a more detailed review. A more detailed review of a sample of existing houses against these standards had been identified as follow on research for months 13-24 of this study.

Reference:  
 ONS (2022) 'Age of the property is the biggest single factor in energy efficiency of homes' View online: <https://www.ons.gov.uk/peoplepopulationandcommunity/housing/articles/ageofthepropertyisthebiggestsinglefactorinenergyefficiencyofhomes/2021-11-01>

## Drawing some interim conclusions from Stage 2.

At this point, the team identified several important observations. We can see that the worst performing assemblies were built prior to the compulsory introduction of insulation to meet U-values in Part L of the Building Regulations i.e., the period from pre-1918 to 1993.

Within this period, we can also see that assemblies built between Pre-1918 and 1979 have similarly thermal performance values for all assemblies: roof, wall and floors.

If we compare this observation to the stock profile for the sample, we can see that the largest quantity of YHG stock were built in this period. Of the 7,818 units included in the sample, 55.5% of this stock was built between pre-1918 and 1979.

We can also see that YHG's stock is not consistent across this period. Of this 55.5%, most stock was built in one of three assembly types:

- 1918-1945 solid construction
- 1945-1959 cavity construction
- 1960-1979 cavity construction

This suggest that refurbishment work would be best concentrated on typical wall, floor, and roof assemblies from these three periods [as reproduced overleaf].

Actual component U values							
Period	Walls (solid)	Walls (cavity)	Floors (on ground)	Floors (suspended)	Roof	Windows	Doors
Pre 1918	1.823 W/m2/K	1.375 W/m2/K	3.977 W/m2/K	2.196 W/m2/K	0.31 W/m2/K	3.3 W/m2/K	3.3 W/m2/K
1918-1939	1.823 W/m2/K	1.779 W/m2/K	4.142 W/m2/K	2.196 W/m2/K	0.31 W/m2/K	3.3 W/m2/K	3.3 W/m2/K
1945-1959	1.485 W/m2/K	1.723 W/m2/K	3.339 W/m2/K	2.196 W/m2/K	0.31 W/m2/K	3.3 W/m2/K	3.3 W/m2/K
1960-1979	1.485 W/m2/K	1.723 W/m2/K	3.339 W/m2/K	1.442 W/m2/K	0.31 W/m2/K	3.3 W/m2/K	3.3 W/m2/K
1980-1993	1.485 W/m2/K	0.477 W/m2/K	3.339 W/m2/K	1.442 W/m2/K	0.31 W/m2/K	3.3 W/m2/K	3.3 W/m2/K

Actual component U values							
Period	Walls (solid)	Walls (cavity)	Floors (on ground)	Floors (suspended)	Roof	Windows	Doors
1994/5-2006	0.45 W/m2/K	0.45 W/m2/K	0.45 W/m2/K	0.45 W/m2/K	0.25 W/m2/K	3.3 W/m2/K	3.3 W/m2/K
2006-2010	0.35 W/m2/K	0.35 W/m2/K	0.25 W/m2/K	0.25 W/m2/K	0.25 W/m2/K	2.2 W/m2/K	2.2 W/m2/K
2010-2021	0.3 W/m2/K	0.3 W/m2/K	0.25 W/m2/K	0.25 W/m2/K	0.2 W/m2/K	2 W/m2/K	2 W/m2/K
2021-present	1.485 W/m2/K	1.723 W/m2/K	3.339 W/m2/K	1.442 W/m2/K	0.31 W/m2/K	3.3 W/m2/K	3.3 W/m2/K

Table 9: worst thermally performing assemblies

Total stock within sample (7,818)			
Ref code	Description	No. of YHG stock	% stock
i.1.1	Pre-1918 solid wall	554	7
i.1.2	Pre-1918 cavity wall	209	2.7
ii.1.1	1918-1945 solid wall	960	12.27
ii.1.2	1918-1945 cavity wall	113	1.4
iii.1.1	1945-1959 solid wall	0	0
iii.1.2	1945-1959 cavity wall	1091	13.95
iv.1.1	1960-1979 solid wall	10	0.13
iv.1.2	1960-1979 cavity wall	1415	18
v.1.1	1980-1993 solid wall	15	0.19
v.1.2	1980-1993 cavity wall	1388	17.75
vi.1.1	1994-2022 solid wall	0	0
vi.1.2	1994-2022 cavity wall	2063	26.39

Table 10: assemblies to form focus for future research



Selected assemblies

1918 - 1944

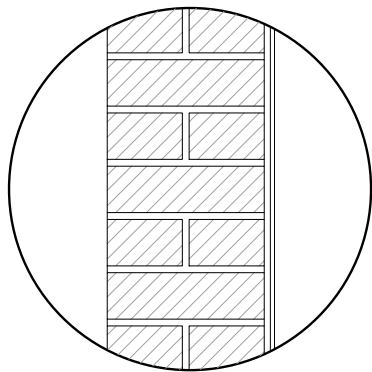

1945 - 1960

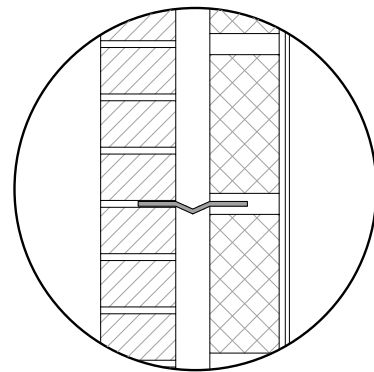

1960 - 1979

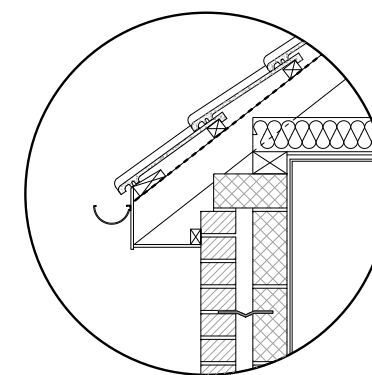
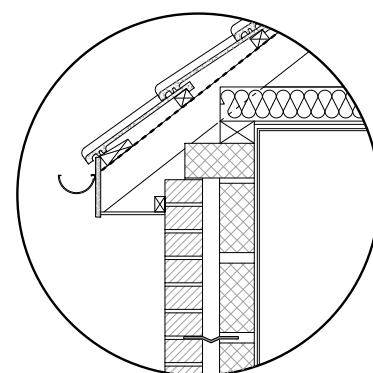
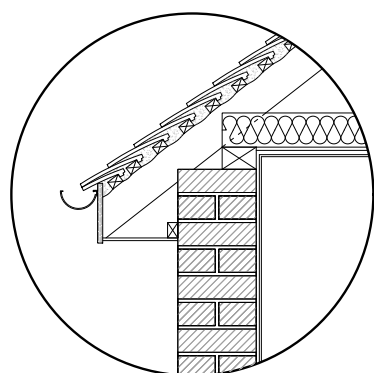
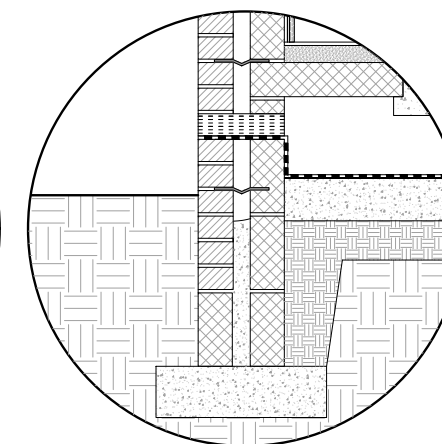
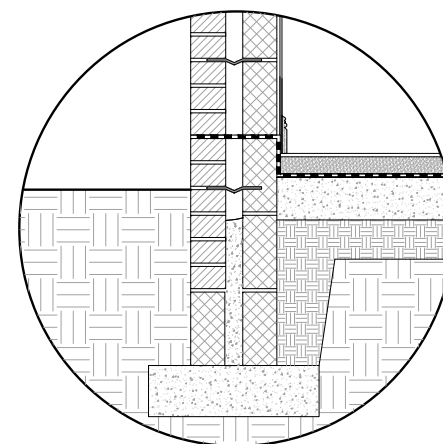
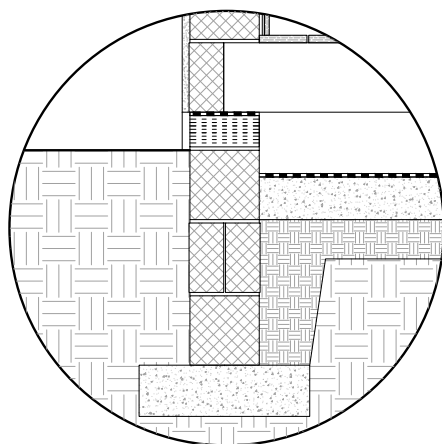
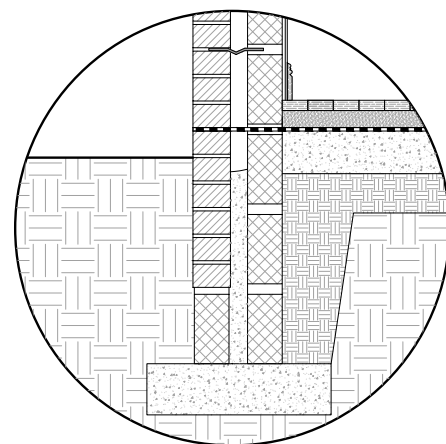
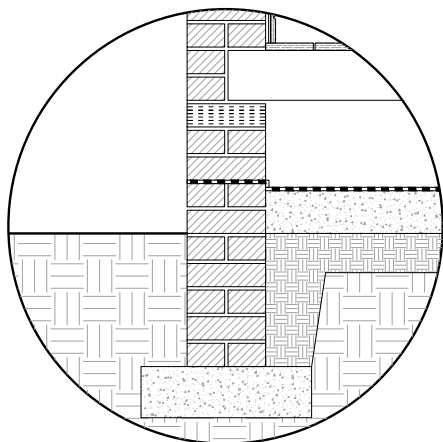
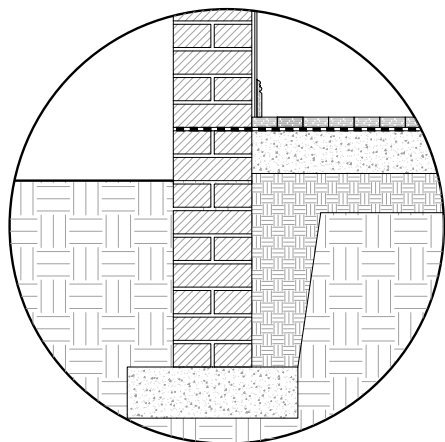
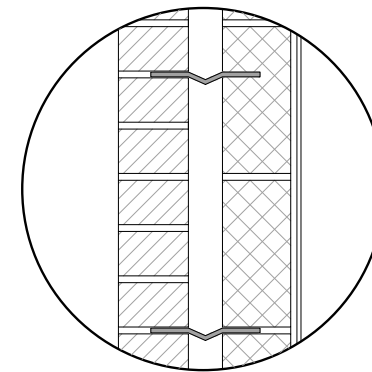

Figure 16: assemblies to form focus for future research

## Improving the energy performance of existing housing stock.

The aim of the second project stage was to review existing housing stock and identify opportunities to improve energy performance and to reduce fuel poverty.

This aim was achieved by:

- Reviewing a database of over 22k units to identify baseline typology of house-types
- Establishing a typology of typical assemblies and junctions (wall-to-floor, wall, wall-to-roof) relevant to these house-types
- Reviewing the operational energy (u values) of these typical assemblies and limitations in their design
- Expanding this database to include EPC data
- Using this data to identify issues associated with energy use and fuel poverty
- Identifying opportunities / strategies for improvement

As noted above, these interim conclusions relate to a dataset of existing stock produced and maintained by YHG. This dataset included several important limitations that impact the way we assess this stock against both targets. Whilst the dataset identifies basic classifications by tenure, type, age, occupancy and EPC rating, it tells us very little about the specific energy use of these units, their architectural features or the M+E systems used for heating, lighting and hot water systems.

With this in mind, the research team considered whether the available information produced through the generation of the EPC certificates could help fill this gap.

Unfortunately, whilst this data exists it is not collated by YHG. YHG have an up-to-date list of EPC scores for their stock, but they do not have the detail associated with these certificates.

The only way that this data could be obtained and collated, therefore, was for the research team to manually download and copy data from each EPC certificate from the publicly accessible records.

The next two stages of Part 2 of the study was used to:

- Obtain this EPC data for a targeted sample.
- Collate the data into a dataset.
- Analyse this dataset to consider energy use and fuel poverty within this target sample.

## Which EPCs / which units?

The YHG dataset identifies EPC scores for each unit. On this basis, the research team could identify which units did not meet the threshold for EPC C (a score of 57).

This exercise showed that there are 2,982 properties in the sample of 7,818 with an EPC score below 57 (below EPC C). This figure was lower than expected based on the thermal envelope assessment covered in Part 3 above.

There are two explanations for this. The first is that the EPC assessment is not only focused on the thermal envelope. A poorly insulated building can have an improved EPC rating by using more efficient heating and lighting systems for example. Secondly, the theoretical study of assemblies in Part 2 focused on as-built designs. It is highly likely that some of the housing stock built between Pre-1918 and 1993 has already been upgraded to some extent. Typically, this may include the addition of mineral wool in the roof space.

## Retrieving EPC data for all 2,982 units

The research team downloaded all EPC data for each of the 2,982 units identified. For completeness, this information was obtained through two different publicly accessible sites and each data entry was obtained and recorded individually. Given the time required to download this information (typically 3 entries per minute), a more extensive dataset to include all 7,818 units and all 22k units would be far beyond the scope of this study and should be considered for future research.

## Opportunities to use the data to refine stage 2

The dataset produced from these EPC records provides numerous opportunities for further research and to refine the insights from Part 2 (above). This data identifies specific wall and roof assemblies for a given unit, which could be matched against the general typologies identified earlier in this study. It also provides information about glazing systems and identifies the nature and extent of any extensions or significant modifications to the properties.

The data identifies heating system types and hot water heating systems as well as basic electrical designs. This could thus be used in future research to generate or inform a more detailed study of the thermal performance of housing stock as a precursor to, or used to inform a detailed thermal model that aligns with the Passive House standard (PhPP10).

## Analysing the data

The research team analysed the data to understand actual energy use within this targeted sample and the implications for fuel poverty.

From the EPD certificates we can identify several relevant pieces of data specific to each unit:

- Energy consumption (kWh)
- Total floor area (m<sup>2</sup>)
- Source of energy for space and hot water heating (mains gas or electricity)
- Estimated space heating for the unit (kWh/A).
- Estimated water heating for the unit (kWh/A).

## Calculating total fuel cost per unit

Using this data, the research team were able to identify the total kWh of gas and the total kWh of electricity in each unit.

Based on the current prices of electricity and gas per kWh (32.05p, 10.55p) the research team could calculate the total cost of gas and electric for each unit and thus the total fuel costs (£).

It should be noted that, whilst EPD certificates also identify fuel costs for the property, these are only relevant to the period when the EPD was conducted. EPDs within this dataset were produced at very different periods and thus represent very different cost values owing to changing fuel prices.

## Calculating household income required

The threshold of fuel poverty is typically assumed to occur when more than 10% of gross income is spent on fuel costs. Using this figure, the team could use the total fuel costs for the unit to identify the household income required to avoid fuel poverty.

Using this simple calculation, the data suggests that the average household income required to avoid fuel poverty was £21.5k per year.

Looking at some of the most extreme cases in this dataset, we may fairly assume that some of the total energy requirements for heating and hot water provided in the EPC certificates are inaccurate. However, given the size of the sample it is fair to assume that this figure is, at least, indicative.

## Fuel poverty

The units covered in this sample range in size and so this figure will be more-or-less achievable depending on the size of the household occupying the property. More in-depth studies are needed to review the accuracy of this data and to obtain more information about the demographic of tenants living in these properties.

But to provide us with an initial indication of fuel poverty based on this limited data, we can assume that the average household would need to have an income based on the equivalent of at least one person over the age of 23 working full time for better than minimum wage (currently £20,319 / year).

## Refurbishment energy strategy

It is beyond the scope of this study to consider M+E strategies to reduce fuel poverty (by fitting solar panels and heat pumps). This was intended for months 13-24. However, we can start to see how this data may serve this purpose. The dataset from EPC certification identifies the total energy required for space and hot water heating. It also provides an indication of the total floor area, number of floors and thus the roof area.

On this basis, future research may consider how many solar panels could be added to the roof of each property; what the expected energy generation would be (kWh) from these panels, and how this would help reduce electrical energy consumption and thus the costs of consumption. As with the points above, such studies should be treated as a 'first pass' and used to direct more targeted surveys and studies.

## Improving the energy performance of existing housing stock.

The aim of the second project stage was to review existing housing stock and identify opportunities to improve energy performance and to reduce fuel poverty.

This aim was achieved by:

- Reviewing a database of over 22k units to identify baseline typology of house-types
- Establishing a typology of typical assemblies and junctions (wall-to-floor, wall, wall-to-roof) relevant to these house-types
- Reviewing the operational energy (u values) of these typical assemblies and limitations in their design
- Expanding this database to include EPD data
- Using this data to identify issues associated with energy use and fuel poverty
- Identifying opportunities / strategies for improvement

(i) What specific and general lessons can be learned from Part 2 of this study?

(ii) What are the next steps in the research?

Observation

*Typologies.* YHG have an existing housing stock of 22k units. This study has identified a logical sample of 10k units for the purpose of analysis. There is significant variation of house-types across this sample. In response to this diversity, this study has produced a novel method of analysis. Using historical research this study has produced 6 historic typologies for walls, floors, and roofs. It has analysed these in terms of thermal performance (U-values) and shown how these types relate to YHG's overall stock profile.

Suggestion

Future research should focus on the following steps:

- To produce refurbishment design solutions for each typology based on U-values, air-tightness and cold bridging risks
- To test these design options against a sample of units identified within the sample. This sub-sample should include a range of variables such as size and occupancy, location relative to the street / pavements, variations associated with planning limitations (permitted development allowances and any protective measures). This test should be based on a detailed measured survey and should account for thermal and cost modelling.

Observation

*Focus.* Of the six typologies, the study identified three typologies which combined very poor thermal performance with high representation within the YHG stock profile:  
(i) 1918-1944 solid construction  
(ii) 1945-1960 cavity construction  
(iii) 1960-1979 cavity construction

Suggestion

Future research / refurbishment strategies should be directed at these three typologies and related to a sample of units within the dataset that are built using these typologies.

Observation

*Data.* The YHG dataset of existing stock does not include EPC data. It only includes scores and assessment dates. EPC data may not be wholly accurate, but it is the most extensive dataset currently available for this housing stock. This study has collated and integrated EPC data for 3,000 units. This provides important insight that could inform future research and refurbishment strategies.

Suggestion

YHG could collate and integrate all EPC data into their master database for the entirety of their housing stock (22k units). Judging by the time taken to collate and integrate data for 3k units this is estimated to take 210 hours. YHG should also review this data for inaccuracies by producing their own surveys for a sample of units within this dataset. This sample could be used to refine the quality of the data.

Observation

*Analysis.* The study has undertaken a rudimentary analysis of the EPC data for a sample of 3,000 units with an EPC score below 57 (EPC C). The data suggest that the average gross household income to avoid fuel poverty would be just over £21k per annum. This initial finding is based on a simple review of the raw EPC data. More in-depth studies are needed to verify this initial finding and to understand how it relates to different occupancies.

Suggestion

As above, future research should be used to verify the EPC data. This data should be used to further explore fuel use, costs, and household income to identify fuel poverty thresholds. This insight could be used to categorise stock and identify priorities for thermal and M+E upgrades. The EPC data could also be used to provide a preliminary assessment of the stock regarding the installation of solar panels and heat pumps.



## Part 3: Communication

### Communicating with tenants to help them reduce energy and plastic use.

The aim of the third project stage was to explore opportunities to reduce energy and plastic use through targeted communications with tenants.

This aim was achieved by:

- Collecting data from a large sample of existing YHG residents based on their energy and plastic use
- Reviewing / analysing this data to establish core themes
- Using the data to identify targeted education pieces for YHG residents



## Communicating with tenants to help them reduce energy and plastic use.

The aim of the third project stage was to explore opportunities to reduce energy and plastic use through targeted communications with tenants

This aim was achieved by:

- Collecting data from a large sample of existing YHG residents based on their energy and plastic use
- Reviewing / analysing this data to establish core themes
- Using the data to identify targeted education pieces for YHG residents

## Stages 1 and 2: surveys and analysis

The aims of these first two stages were to:

- Understand how existing YHG tenants use plastic and energy in their homes.
- Identify themes that could be used to produce targeted advice to help tenants reduce energy and plastic use.

Working closely with YHG, the research team established a methodology for a survey to be distributed by YHG across their tenancy database. To ensure data security, YHG was responsible for collecting, collating, and managing the dataset.

YHG distributed the survey to over 9,000 tenants via email, the survey link was sent to over 7,000 tenants via text and included on the YHG social media platforms.

1,609 tenants responded to the survey.

Key findings from the study are set out in a 22-page report entitled: 'Sustainability survey: October 2022: Customer Results and Insights'

This report is reproduced over the following pages.



# SUSTAINABILITY SURVEY

October 2022: Customer Results and Insights  
 Rachel Deeks, Customer Insight Analyst

Creating more places for people to thrive and be recognised as a sector leading landlord



## SURVEY REPRESENTATION SUSTAINABILITY SURVEY FY23

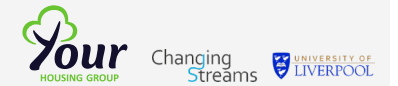

Survey Representation by Property Type

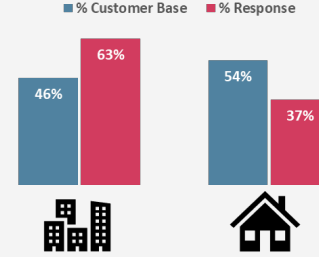

Customers residing in **flats** are **over-represented** in the survey response with 63% compared with 46% of the customer base.

Survey Representation by Age Group

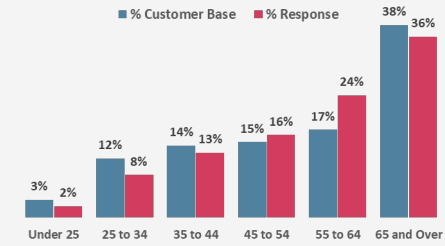

Customers in the **55 to 64 age group** are **over-represented** in the survey response with 24% compared with 17% of the customer base.

Survey Representation by Tenure Type

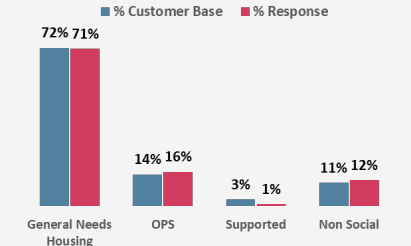

These charts show that the survey response is largely representative of tenure types.

## HEADLINES SUSTAINABILITY SURVEY FY23



The Sustainability Survey launched in October 2022. It was sent to over nine thousand customers with an email address on record; the survey link was sent to seven thousand plus customers by text, and was included on our social media platforms. The aim of the survey was to engage with customers on their energy and plastic usage, to help inform future programmes and will be used to inform YHG's cost of living project.



1,609 Survey responses

62% of respondents say **heating** contributes the most towards energy costs in the home

52% of respondents believe that there is **little they can do to reduce energy costs in the home**

49% of respondents believe that **all** plastic should be sent for recycling



69% would like a guide with tips on **reducing energy costs**

57% would like a guide with tips on **reducing their plastic footprint**

30% have a **pre-payment meter**

58% of these have a **smart meter**

# SUSTAINABILITY SURVEY ENERGY EFFICIENCY



Creating more places for people to thrive and be recognised as a sector leading landlord

# TOP 3 ENERGY COSTS IN YOUR HOME - RANKED

## SUSTAINABILITY SURVEY FY23

Customers were asked "what do you think are the top 3 energy costs in your home?". They were then asked to rank these choices in priority order from highest cost downwards. Of the 1,609 respondents to the survey: 1,471 ranked 3 options; 22 ranked 2 options; 34 selected 1 option; and 82 did not respond to this question.

62% of responding customers tell us that heating is the highest energy cost in their home.

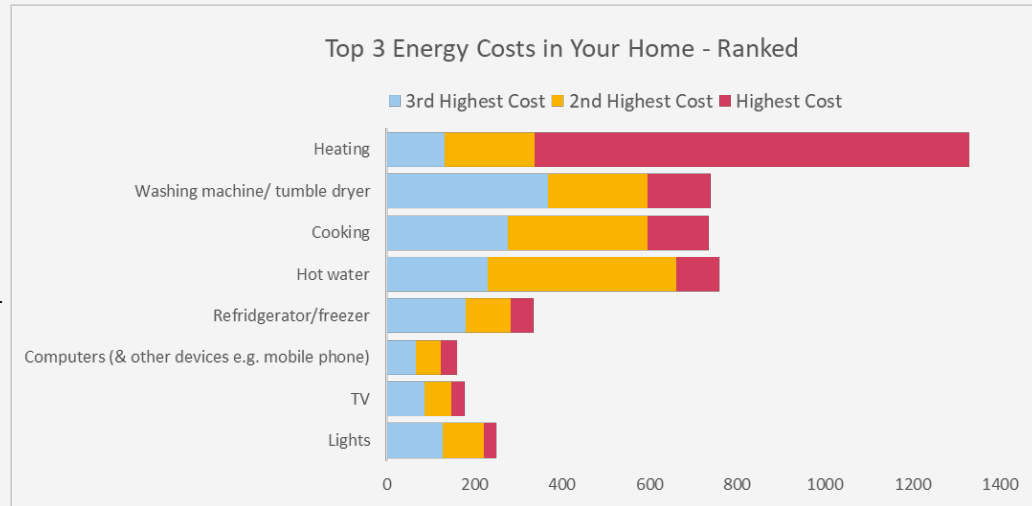

# TOP ENERGY COST - SPLIT BY AREA

## SUSTAINABILITY SURVEY FY23

Please choose what you think is the top energy cost in your home:	Liverpool	Warrington	Manchester	Staffordshire Moorlands	Stockport	Preston	Birchwood	Chester	Wigan	Blackburn	Partington	Leeds	Crewe
Heating	67%	62%	65%	65%	72%	66%	69%	59%	63%	63%	60%	57%	53%
Cooking	10%	11%	9%	8%	7%	11%	7%	13%	7%	7%	13%	11%	10%
TV	1%	2%	1%	3%	3%	2%	1%	2%	1%	5%	-	-	5%
Computers (& other devices e.g. mobile phone)	2%	2%	5%	5%	1%	4%	1%	-	-	2%	4%	-	-
Hot water	5%	9%	10%	6%	4%	4%	2%	8%	4%	3%	7%	20%	5%
Lights	3%	2%	2%	1%	1%	1%	1%	3%	1%	2%	2%	2%	3%
Washing machine/tumble dryer	11%	9%	6%	10%	6%	8%	11%	8%	16%	14%	13%	5%	25%
Refrigerator/freezer	2%	3%	2%	2%	5%	3%	7%	6%	6%	5%	2%	5%	-
Number of Responses	227	208	174	145	137	91	84	86	68	59	55	44	40

This table shows the distribution of top energy costs across those areas who had a response of 40 or more. The RAG colours show the highs and lows across the category (row) with more respondents from Stockport citing "heating" as the main cause, than any other area.

# TOP ENERGY COST - SPLIT BY AGE GROUP

## SUSTAINABILITY SURVEY FY23



- 62% of responding customers tell us that heating is the highest energy cost in their home. Customers in age groups of 55+ are over represented in this category when compared with the respondent population (depicted with dotted lines).
- 9% of responding customers tell us that using the washing machine or tumble dryer is the highest energy cost in their home. This category is over represented by customers between the ages of 25-34 and 35-44, this finding is expected as these age groups tend to have larger households.

Notes on charts: These charts show the percentage of customers in each age group who selected that option as the top contributor to energy cost within the home. The dotted lines show the representation of the entire survey by age group. Those customers who responded to the survey link attached to social media posts where asked to provide their address details, those who did not do so are represented in the charts as "unknown".

# TOP ENERGY COST - SPLIT BY CUSTOMER TYPE

## SUSTAINABILITY SURVEY FY23

SDR Category	Responses	Heating	Cooking	TV	Computers (& other devices e.g. mobile phone)	Hot water	Lights	Washing machine / tumble dryer	Fridge / freezer
General Needs Social Rent	752	68%	7%	2%	2%	6%	2%	11%	2%
Housing for Older People	137	56%	19%	1%	4%	6%	3%	4%	6%
General Needs Social Rent Over 55	129	72%	9%	-	-	5%	1%	10%	4%
Leasehold 100% equity	101	71%	9%	-	3%	9%	1%	5%	2%
LCH Less than 100% equity	97	62%	7%	3%	1%	7%	3%	12%	4%
GN Affordable Rent	94	56%	12%	3%	4%	6%	-	14%	4%
Market Rent	37	57%	5%	3%	8%	16%	-	8%	3%
Housing for Older People PFI	24	71%	8%	4%	-	8%	-	-	8%
OPSAffordable Rent	22	59%	0%	5%	9%	5%	5%	18%	5%
Keyworker	22	55%	9%	5%	-	5%	-	8%	23%
Headrow GN Market Rent	12	83%	8%	-	-	-	-	8%	-
LCH with full equity share bought	9	78%	22%	-	-	-	-	-	-
Supported	9	22%	22%	11%	11%	11%	11%	11%	11%
Intermediate Rent	8	50%	0%	0%	13%	25%	-	13%	-
LCH Less than 100% equity PFI	4	25%	0%	25%	-	-	-	50%	-
Private Care Line	3	33%	33%	-	-	33%	-	-	-
Temporary Supported	3	67%	33%	-	-	-	-	-	-
Leasehold 100% equity PFI	2	-	-	50%	-	-	-	50%	-
Freehold with Service Charge	2	100%	-	-	-	-	-	-	-
General Needs Social Rent PFI	2	100%	-	-	-	-	-	-	-
Student	2	100%	-	-	-	-	-	-	-
GN Affordable Rent Over 55	2	-	50%	-	-	50%	-	-	-
Headrow OPS Market Rent	1	100%	-	-	-	-	-	-	-
Specialised Supported	1	100%	-	-	-	-	-	-	-
Shared Equity Leasehold	1	100%	-	-	-	-	-	-	-

Note: The numbers on this page do not add to the total number of responses on page 2 as it was not possible to identify all customers who responded to the link attached to social media posts.

## HOW DO YOU TRY TO SAVE MONEY ON ELECTRICITY? SUSTAINABILITY SURVEY FY23

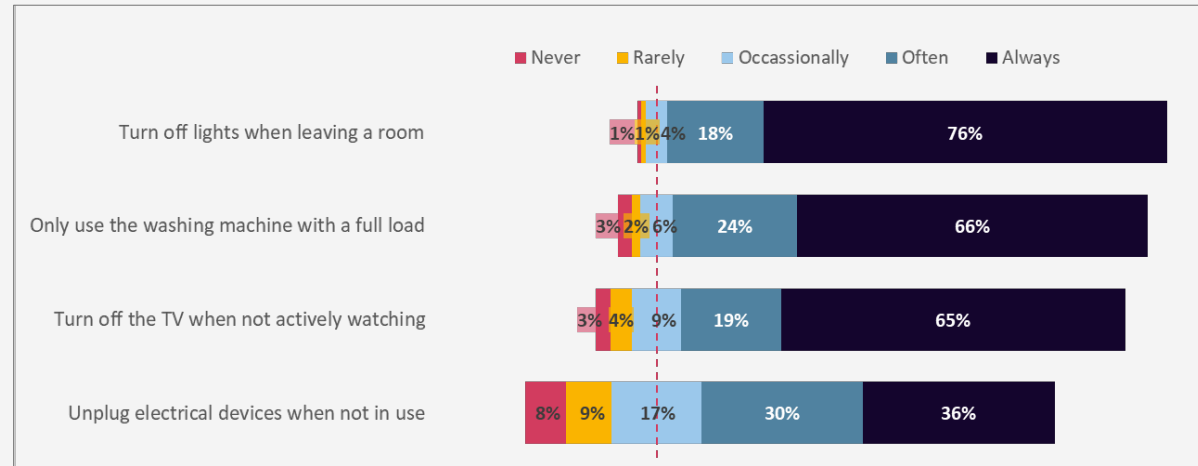

- 94% of responding customers tell us that they “always” or “often” turn off the lights when leaving the room;
- 90% “always” or “often” only use the washing machine with a full load;
- 84% “always” or “often” turn off the TV when not actively watching;
- 67% “always” or “often” unplug electrical devices when not in use.

## HOW FAR DO YOU AGREE WITH THE FOLLOWING...? SUSTAINABILITY SURVEY FY23

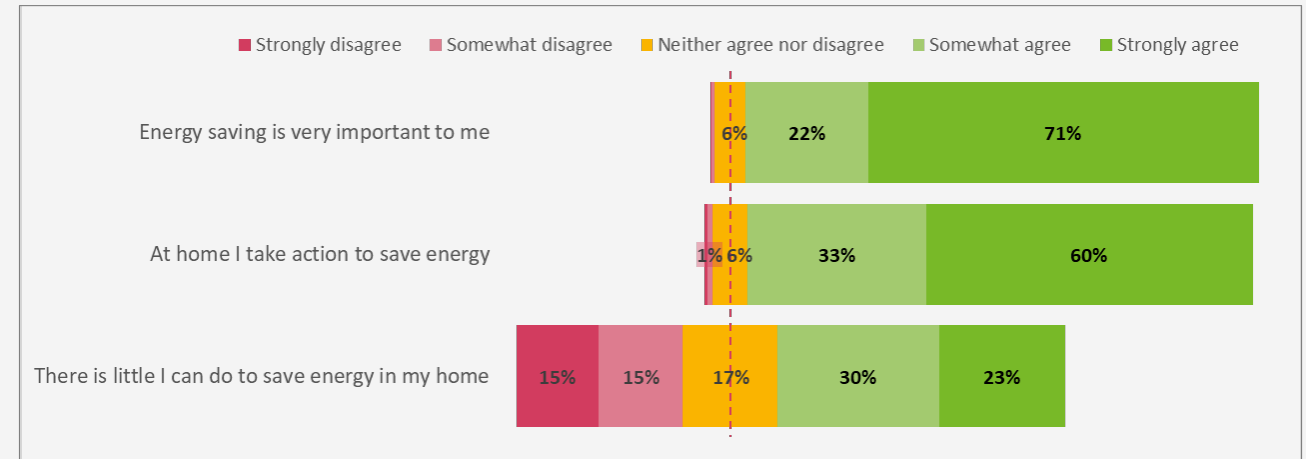

- 93.5% of responding customers tell us that saving energy is *very important* to them, but 52.5% say that they feel there is *little they can do* to save energy in their home. This feeling of not being able to do anything is strongest in the 35-44 age group.

## HOW DO YOU TRY TO SAVE MONEY ON ELECTRICITY? SUSTAINABILITY SURVEY FY23

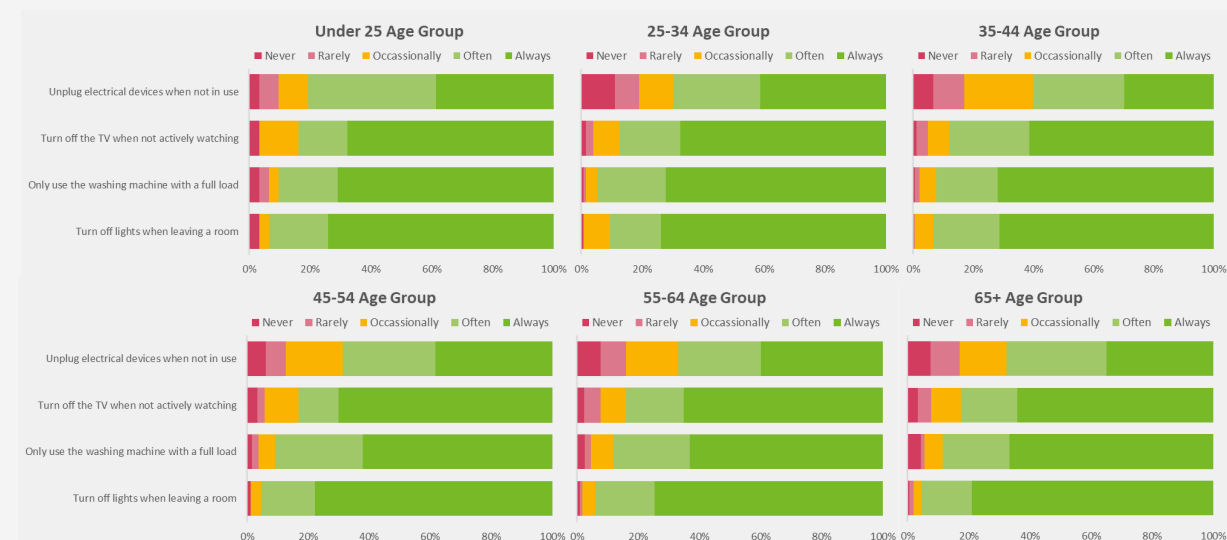

The age group who are least likely to **unplug electrical devices when not in use** are **35-44 year olds** (188 respondents) with 60% saying they do this “always” or “often” – the average for all year groups is 67%. Whereas, the age group most likely to unplug electrical devices are **under 25’s** (35 respondents) with 81% saying they do this “always” or “often”.

## ‘THERE IS LITTLE I CAN DO TO SAVE ENERGY?’ SUSTAINABILITY SURVEY FY23

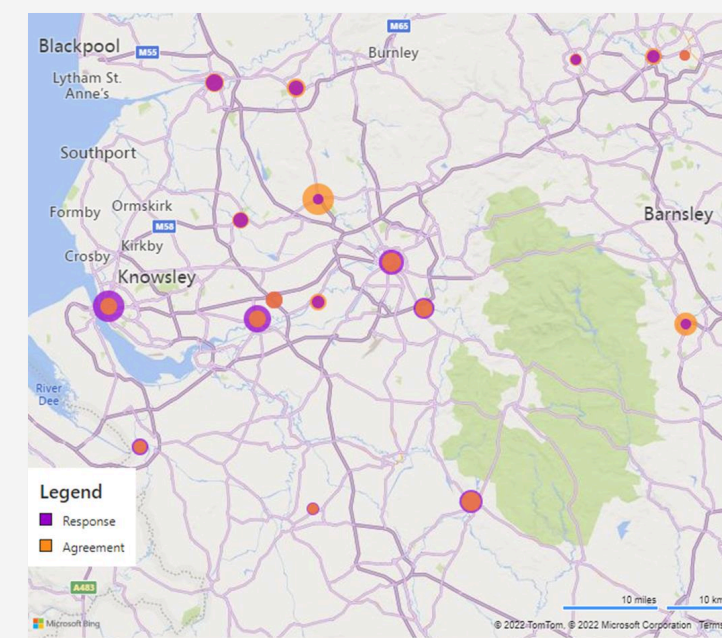

52% of respondents either ‘agree’ or ‘strongly agree’ with the statement “there is little I can do to save energy in my home”.

This is broken down by areas with 40 or more responses. The size of the orange circle on the map indicates a higher agreement, and the size of the purple circle shows a higher response. The numbers in red in the table show those higher than the 52% average.

Agreement that “there is little I can do to save energy” by Area with 40 or more responses		
Area	Responses	Agreement
Liverpool	252	51%
Warrington	227	52%
Manchester	180	58%
Staffordshire Moorlands	167	56%
Stockport	142	50%
Preston	100	57%
Birchwood	87	53%
Chester	86	44%
Wigan	72	52%
Blackburn	63	59%
Partington	58	51%
Leeds	50	54%
Crewe	40	35%



# GUIDANCE ON HOW TO MAKE ENERGYSAVINGS

## SUSTAINABILITY SURVEYFY23

15% of respondents (283) said that they would ask YHG for guidance on how to make energy savings (chart top left).

Customers were asked "where would you seek guidance on how to make energy savings?", and were provided with four options, of which they could select more than one response. There was also an option for "other" with a text box to provide more information. The chart on the right shows the breakdown of the "other" category, and the quotations below were general comments provided in this section.

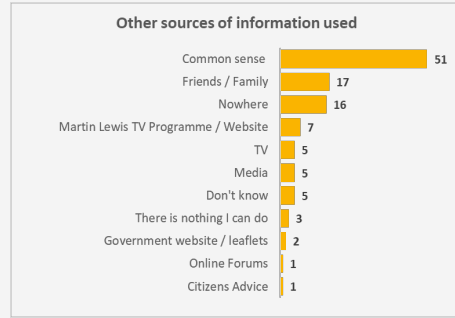
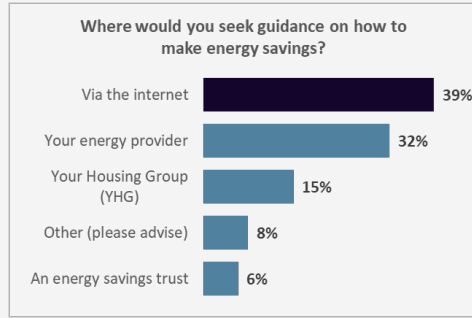

“Well my home is draughty sometimes as my front door has big gaps and needs draught excluders between the gaps. There's no point putting heaters on, it just wastes money.”  
 “Thick curtains, draught excluders, keeping doors closed.”  
 “Storage heating is very expensive. No advice can resolve dilemma of being cold and saving costs or being warm and unaffordable.”  
 “Loft insulation.”  
 “Insulate hot water tank.”  
 “End of block flat so cost more to heat.”  
 “During boiler repair I asked advice was beneficial.”  
 “Although I try to save energy I believe this crisis is planned.”

# DO YOU HAVE A PRE-PAYMENT METER?

## SUSTAINABILITY SURVEYFY23

30% of responding customers say they have a pre-payment meter.

39% of responding General Needs customers (407) have pre-payment meters. 76% of these (310) are from the General Needs Social Rent SDR category.

The 45-54 age group have the highest percentage of pre-payment meters with 47%.

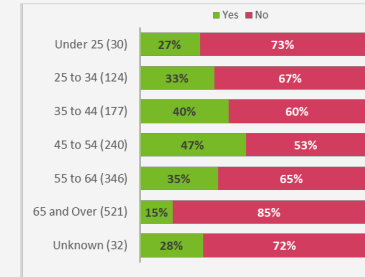
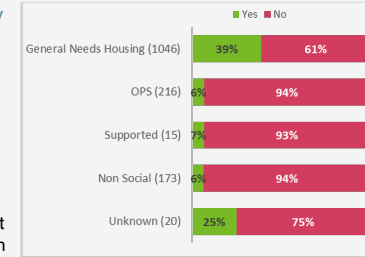

The figures on these charts differ slightly as some respondents to the social media linked survey only provided partial address details.

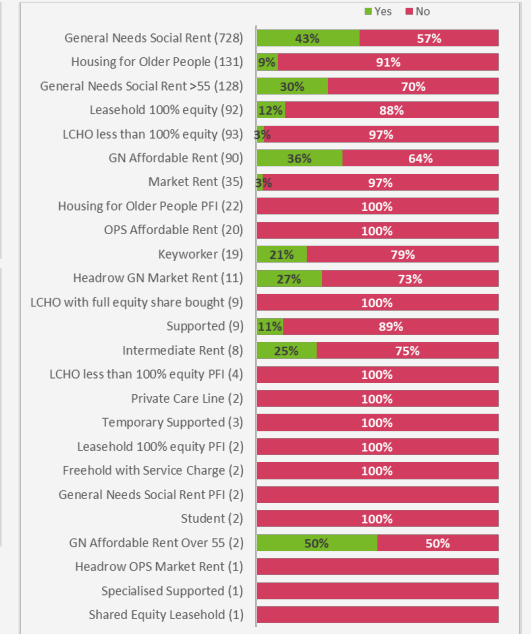

# RECEIVE A GUIDE ON HOW TO MAKE ENERGYSAVINGS?

## SUSTAINABILITY SURVEYFY23

69% of respondents (1,021 out of 1,470) said they would like to receive a guide from YHG on how to make energy savings.

This number has been split out by age and tenure type in the charts to the right (number of respondents per category is shown in brackets).

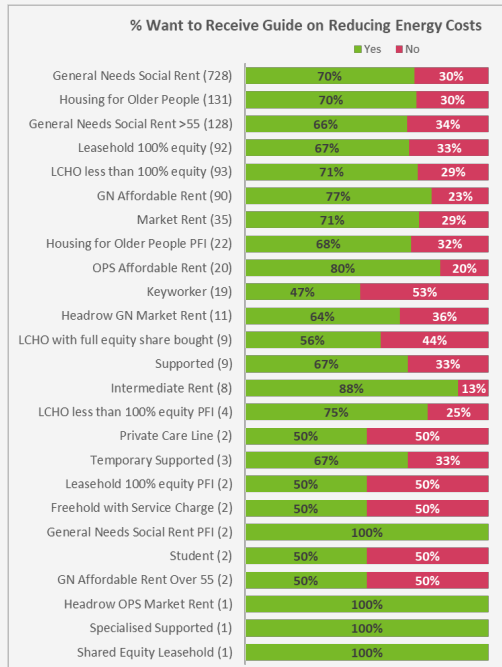
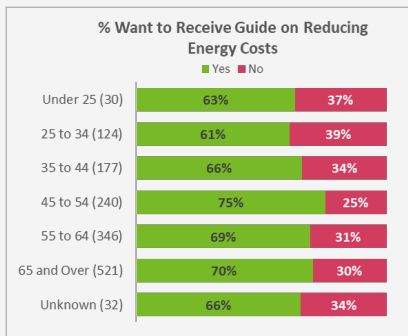

# DO YOU HAVE A SMART METER?

## SUSTAINABILITY SURVEYFY23

58% of those with a pre-payment meter, say it is a smart meter (256 respondents). This equates to 17% of all respondents.

59% of responding General Needs customers with a pre-payment meter have a smart meter (239 respondents). 79% (188) of these are in the General Needs Social Rent SDR category.

The 25-34 age group have the highest percentage of smart meters with 66% (27 out of 41 respondents).

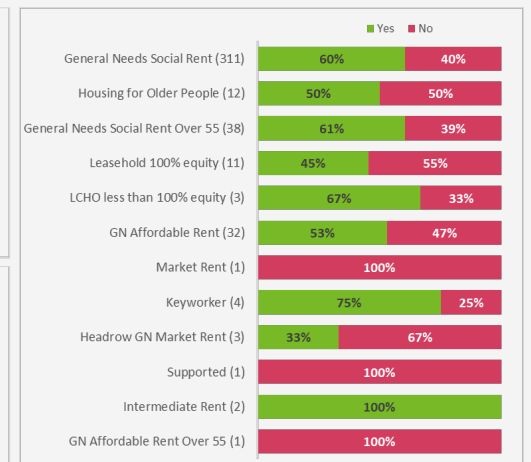
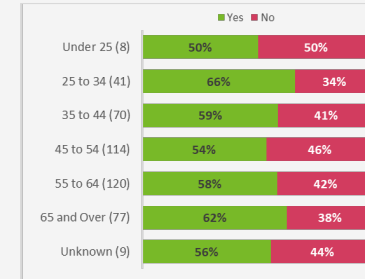
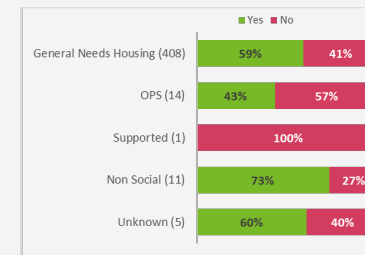

The figures on these charts differ slightly as some respondents to the social media linked survey only provided partial address details.

# SUSTAINABILITY SURVEY PLASTICS AND RECYCLING



Creating more places for people to thrive and be recognised as a sector leading landlord

## HOW FAR DO YOU AGREE WITH THE FOLLOWING...? SUSTAINABILITY SURVEY FY23

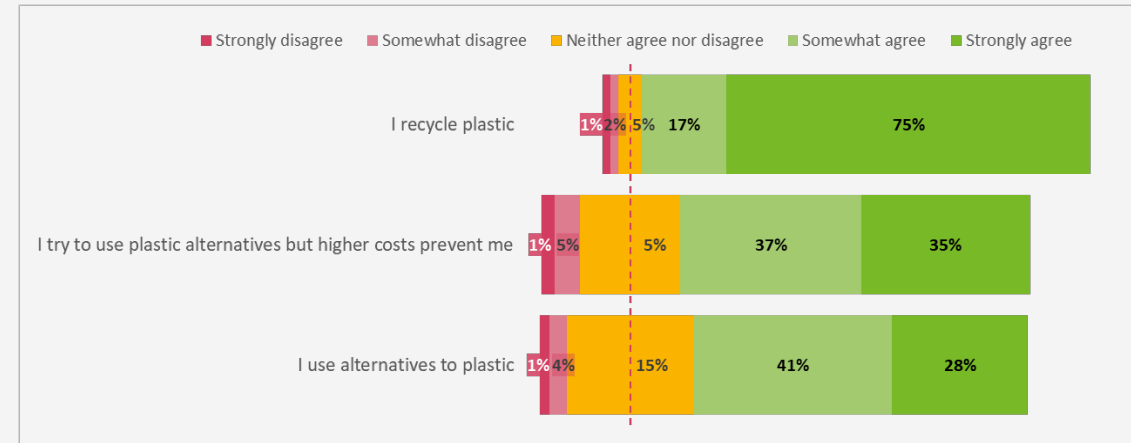

## PLASTIC REDUCTION SUSTAINABILITY SURVEY FY23

Customers were asked “from the list below, please indicate how strongly you agree or disagree with the following statements about single use plastic?”

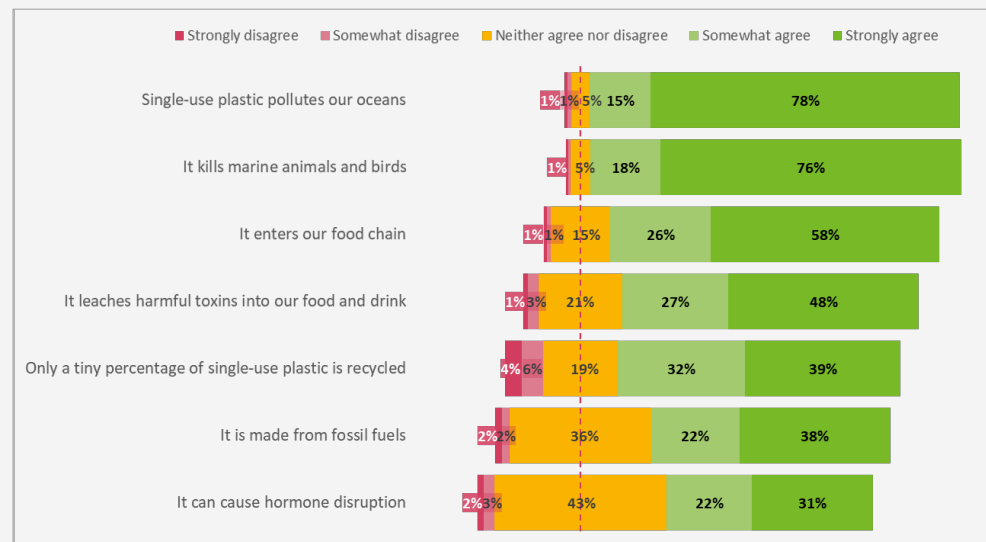

## RECYCLING HABITS – BROKEN DOWN BY AGE GROUP SUSTAINABILITY SURVEY FY23

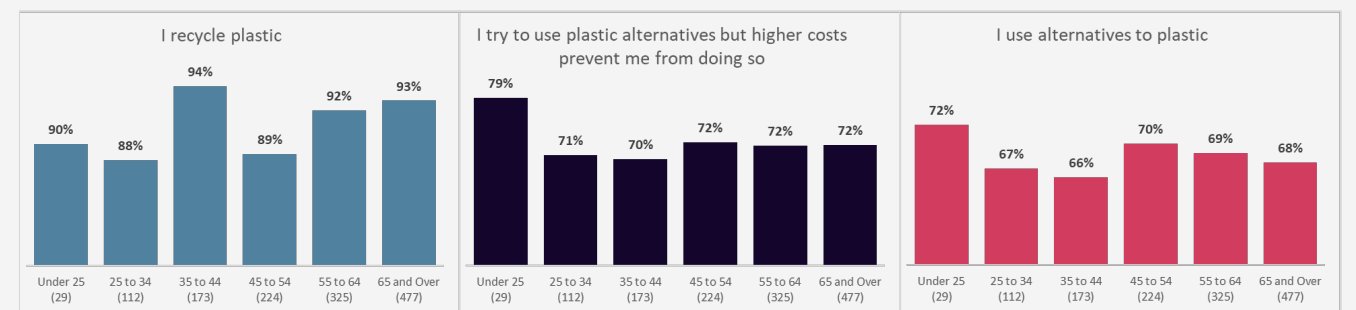

- The findings of the survey indicate the **35-44 age group** (173 respondents) are most likely to recycle but least likely to use alternatives to plastic.

# WHAT PERCENTAGE DO YOU THINK SHOULD BE SENT FOR RECYCLING IN 2022?

## SUSTAINABILITY SURVEY FY23

Almost 50% of respondents feel that **all** plastic packaging should be recycled.

The chart on the right shows the percentage broken down by age group. The chart on the far right shows the age distribution of the report for comparative purposes.

Some customers provided commentary for this question and this is presented on the following page.

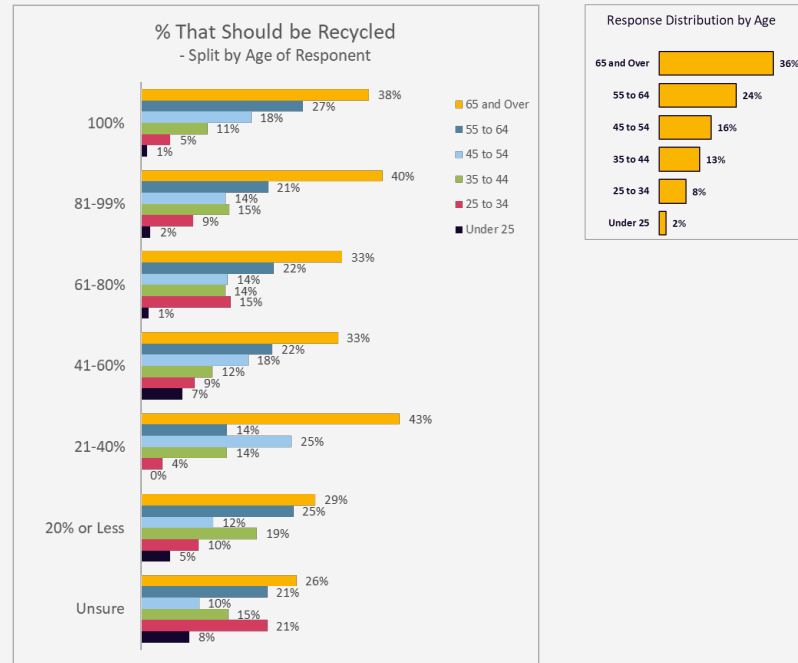
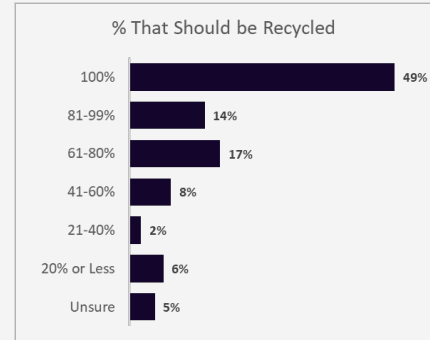

# WHAT PERCENTAGE DO YOU THINK SHOULD BE SENT FOR RECYCLING IN 2022?

## SUSTAINABILITY SURVEY FY23

“100%. At **Brunswick Gardens** we have no facilities to recycle plastics, it's shameful.”

“Recycling is useless as it's in a **landfill** half the time.”

“100%, but **reduction** in usage is vastly more important.”

“100% would recycle more plastic items but **Trafford** won't accept them.”

“100% but it should be up to the **manufacturers** to make more plastic recyclable.”

“100% It depends on the plastic: New bio degradable plastics are in development, some plastics are cellulose substrates etc.”

“The **large corporations** who converted us to plastic packaging are solely responsible for the plastic footprint and should therefore bare the brunt of recycling 100% of all plastics.”

“We should aim to **reduce or eliminate** single use plastic. There are no recycling facilities at this site.”

“I find **Yorkshire** very lax on what it accepts so feel it could be increased somewhat.”

“Unable to recycle due to my recycle bins being constantly **stolen**.”

“Should be as much as possible. I'm **dubious** though about how much is really recycled - I have a suspicion that the centres dealing with recycling might not do as much as claimed.”

“**Not interested** in green agenda.”

“If **you provide bags** it would be 90 per cent.”

“Plastic is **expensive to recycle** and in the majority of cases cannot be viable recycled.”

“It should all be sent, but too many people are **too lazy** to wash it out.”

“Depends **where** it is getting recycled? China?”

“We should aim to reduce or eliminate single use plastic. There are **no recycling facilities** at this site.”

“All of it if it cannot be recycled. **Use something else** to package it.”

“I'm not entirely sure on a precise percentage but I do think **more recycling options** should be available via the council.”

“I think **all** plastic should be recycled or banned. I always use my recycled plastic bags. I also have started buying everything that is refillable. I switch off all the utensils and unplug TVs as I can.”

“I send about 70% for recycling but **local authority** says 87% of all is only suitable for dumping!”

“We **don't** have recycling here.”

“**When large companies** do I will.”

“**What the manufactures and government** agree on.”

“It's not where it is sent for recycling, it's **where it ends up** in other countries as waste.”

“All of it for **recycling or safe disposal**.”

“As much and as **economically feasible** %???”

“Reading **undercover reports** an watching video exposes. Many authorities are unable due to cost constraints to recycling. This has been confirmed by a friend who is employed in the service.”

“Not sure on an exact number but everyone should strive and I think the UK is one of the highest for recycling which I take some **pride** in.”

“We should be able to recycle 100% of plastic - **AND** glass, which is currently not collected so ends up in the general rubbish.”





## Communicating with tenants to help them reduce energy and plastic use.

The aim of the third project stage was to explore opportunities to reduce energy and plastic use through targeted communications with tenants

This aim was achieved by:

- Collecting data from a large sample of existing YHG residents based on their energy and plastic use
- ~~Reviewing / analysing this data to establish core themes~~
- Using the data to identify targeted education pieces for YHG residents

### Stage 3: targeted education / communication pieces

Themes from the data were used to identify and produce targeted education pieces.

Key themes / insights were translated into core messaging and tips. These formed the basis for four concept designs.

The following pages include extracts from two of these concept designs.

These sample documents were produced at the end of the research period. It is advised that the YHG team should review these documents and issue a selection to all tenants before undertaking a 'follow-up' survey to assess their usefulness in practice.

# TOP TIPS TO HELP YOU IN YOUR HOME



## HOW TO MAKE ENERGYSAVING AND REDUCE PLASTIC IN YOUR NEW HOME

Your Housing Group looking after your interests



In partnership with  
Changing  
Streams



# TOP TIPS TO MAKE ENERGYSAVING IN YOUR HOME



1. Don't overfill the kettle



2. Use energy efficient appliances



3. Reduce your dishwasher usage

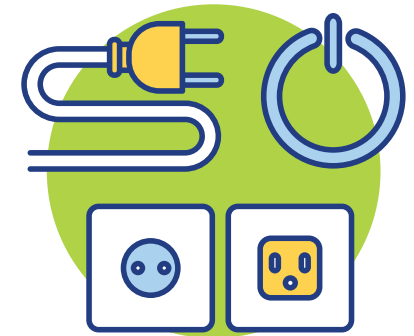

4. Unplug appliances if not in use

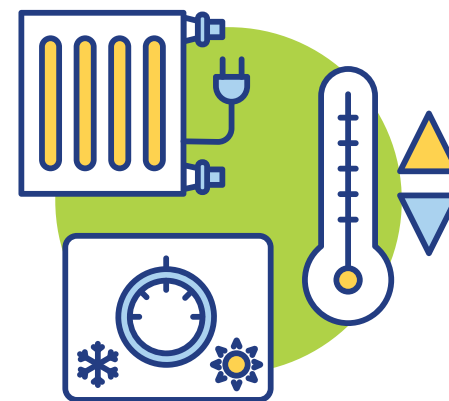

5. Control heating temperatures

### MORE TOP TIPS

- Draught-proof gaps in windows & doors
- Turn off the lights
- Wash at 30 degrees
- Avoid using the tumble dryer
- Take a 4-minute shower
- Swap one bath a week for a shower
- Insulate your hot water cylinder



Your Housing Group | Changing Streams

**TOP TIPS**

# TO REDUCE PLASTIC IN YOUR HOME



**1.** Clean your home with natural ingredients

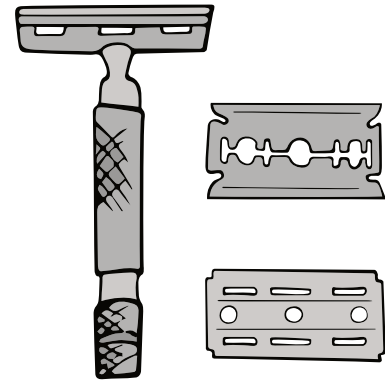

**2.** Invest in a stainless steel razor



**3.** Brush with bamboo



**4.** Use an eco friendly shopping bag

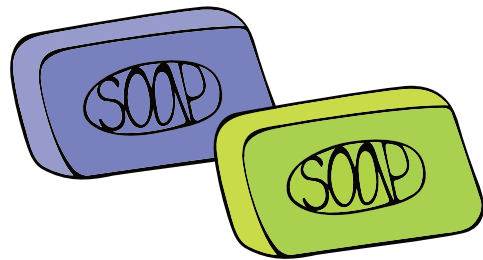

**5.** Use soap bars instead of bottles

**MORE TOP TIPS**

- Use natural oils to cleanse & moisturise
- Choose plastic-free natural deodorant
- Pack your lunch in reusable containers
- Say no to disposable straws & cutlery
- Carry a reusable water bottle
- Store leftovers in glass jars



Your Housing Group | Changing Streams

**TOP TIPS**

TO HELP YOU MAKE ENERGY SAVINGS AND REDUCE PLASTIC IN YOUR HOME



## ENERGY SAVINGS IN YOUR HOME

## PLASTIC REDUCTION IN YOUR HOME



Your Housing Group looking after your interests



In partnership with  
Changing Streams

## TOP TIPS

### TO MAKE ENERGY SAVINGS IN YOUR HOME



1. Don't overfill the kettle
2. Use energy efficient appliances
3. Reduce your dishwasher usage
4. Unplug appliances if not in use
5. Control heating temperatures
6. Use cold water instead of hot
7. Don't leave electrical appliances on standby

#### MORE TOP TIPS

- Draught-proof gaps in windows & doors
- Turn off the lights
- Wash at 30 degrees
- Avoid using the tumble dryer
- Take a 4-minute shower
- Swap one bath a week for a shower
- Insulate your hot water cylinder

SAVE  
ENERGY



## TOP TIPS

### TO REDUCE PLASTIC IN YOUR HOME



1. Clean your home with natural ingredients
2. Use soap bars instead of bottles
3. Brush with bamboo
4. Use an eco friendly shopping bag
5. Invest in a stainless steel razor
6. Use natural oils to cleanse & moisturise
7. Choose plastic-free natural deodorant

#### MORE TOP TIPS

- Pack your lunch in reusable containers
- Say no to disposable straws & cutlery
- Carry a reusable water bottle
- Store leftovers in glass jars
- Use natural sponges or a luffa
- Say NO to single-use plastic bottles

REDUCE  
PLASTIC

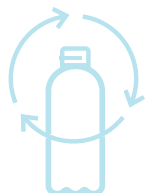

(i) What specific and general lessons can be learned from Part 3 of this study?

(ii) What are the next steps in the research?

### Observation

*Survey results.* The survey identified several important points. In relation to insight from Part 2, it reinforced the observation that heating is a significant contributor to the energy costs of a home. More specifically to Part 3, it demonstrates that there is a strong case for developing targeted guidance for tenants to reduce energy and plastic use.

### Suggestion

As with most surveys, the quality of the data is limited because it is based on structured and generic questions. Future research could be used to further unpack these general themes and observations. Such studies may be developed through less structured questionnaires or/and semi-structured interviews. These insights could be used to further enhance the advice and tips contained within targeted education pieces.

### Observation

*Targeted education / communication pieces.* This stage of the study was limited to developing draft education / communication pieces informed by the survey data.

### Suggestion

The usefulness of these education / communication pieces can only be judged once they are circulated. Further research may be used to pilot these documents on a small population of tenants. Ideally this sample would align with the recommended sample and findings from Part 2. This sample population would potential benefit most from reduced energy consumption.